



SECTION 7

COMPONENT ACCESS AND REMOVAL



COMPONENT ACCESS AND REMOVAL

This section explains how to adjust, access and/or remove 700-3 Series base unit components. If different models have similar procedures, they are grouped together under the appropriate heading. The units covered in the procedures are listed between brackets after the heading.

This section is arranged as follows: Page:
• Exterior Cosmetic / Mechanical Components 7-3
• Interior Cosmetic / Mechanical Components 7-5
• Compressor Area Mechanical Components 7-15
• Sealed System Components 7-20

An attempt has been made to arrange these procedures in such a way as to simulate which components would need to be removed first in order to gain access to other components. When following a component removal procedure, it may be necessary to reference another component removal procedure listed earlier in this section.

NOTE: Before continuing, please take note of the WARNINGS and CAUTIONS below.

Warning box containing three bullet points: IF IT IS NECESSARY TO REMOVE A UNIT FROM ITS INSTALLATION, REMEMBER THAT THE UNIT COULD TIP FORWARD... TO AVOID ELECTRIC SHOCK, POWER TO THE UNIT MUST BE DISCONNECTED... IF REMOVING A DRAWER REMEMBER THAT DRAWERS ARE HEAVY.

Caution box containing two bullet points: If working in the compressor area, remember that compressor and tubing may be hot. If working on or around the evaporator or condenser, remember that evaporator and condenser fins are sharp.

EXTERIOR COSMETIC AND MECHANICAL COMPONENTS

Kickplate/Grille Removal (All Base Units)

The kickplate/grille is attached by four screws passing through the kickplate into adjustable kickplate brackets.

NOTE: Because drawer panels may extend down in front of the kickplate/grille, it may be necessary to remove the bottom drawer to gain access.

To remove the kickplate/grille, extract the four screws (two on each side), then pull kickplate/grille forward. (See Figure 7-1)

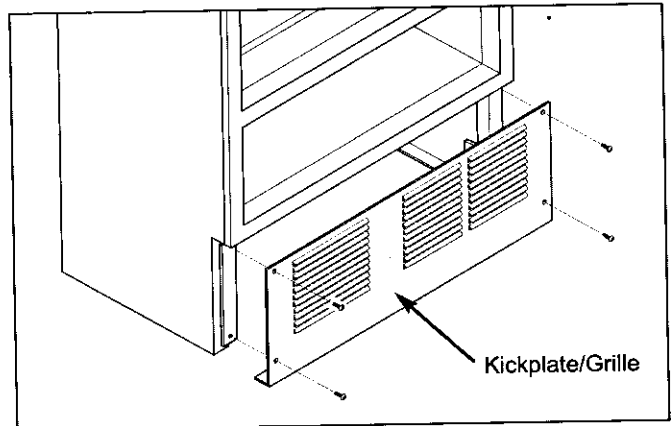

Figure 7-1. Kickplate/Grille Removal

Drawer Assembly Removal (All Base Units)

There are inverted channels on both sides of the drawer tubs which rest on telescoping drawer slide assemblies. A pin at the front of each drawer slide fits into a hole in the inverted channel of each drawer tub, holding the drawer assembly in place. (See Figure 7-2)

CAUTION

Top drawer has a display wire harness that must be disconnected during top drawer removal. Failure to disconnect wire harness could damage wiring or connections. See top drawer assembly removal procedure below.

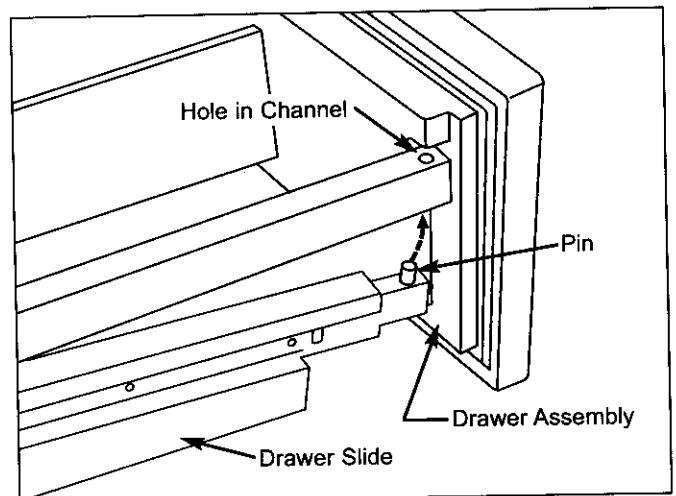

Figure 7-2. Drawer Assembly Removal

Top Drawer Removal:

1. Pull top drawer assembly open 6 to 10 inches.
2. Lift front of drawer up and off of pins at end of drawer slides, then push slides back in (See Figure 7-2).
3. Carefully place drawer assembly face down directly in front of unit.
4. Disconnect control cable at interior left rear of unit by turning collar on connector counterclockwise and unplugging pins from socket (See Figure 7-3).

Bottom Drawer Removal:

1. Pull bottom drawer open and lift front up and off of pins at end of drawer slides (See Figure 7-2).
2. Continue pulling drawer assembly forward and out. Then, push telescoping drawer slide assemblies back in.

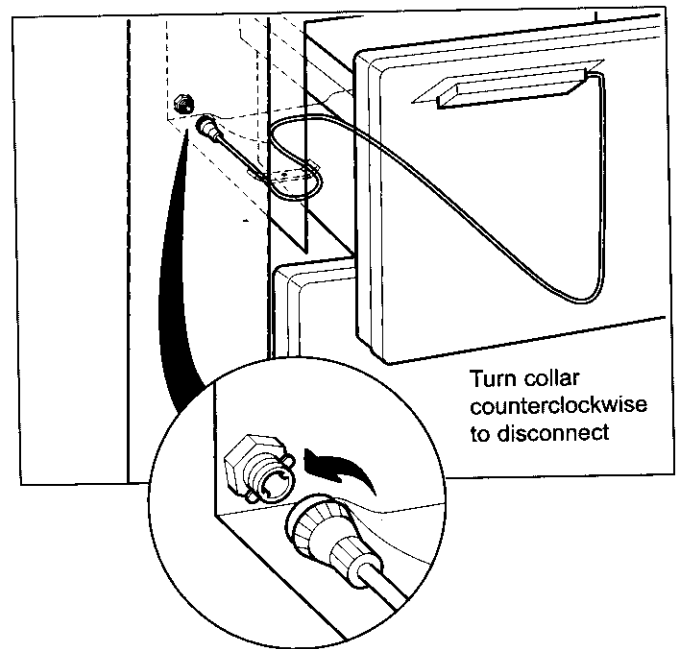

Figure 7-3. Disconnecting Control Cable

Side Trim Molding Strip Removal (All Base Units)

Side trim molding strips are held in place by two unit-to-cabinet brackets which are attached to the sides of the cabinet.

NOTE: Removing the drawers first will make this task easier.

To remove side trim molding strips (See Figure 7-4):

1. Insert a straight-blade screwdriver in channel at bottom of molding, then gently pull molding forward until face-frame edge of molding is accessible.
2. Place another straight-blade screwdriver under face-frame edge and gently work molding away from face-frame and out of the two unit-to-cabinet brackets.

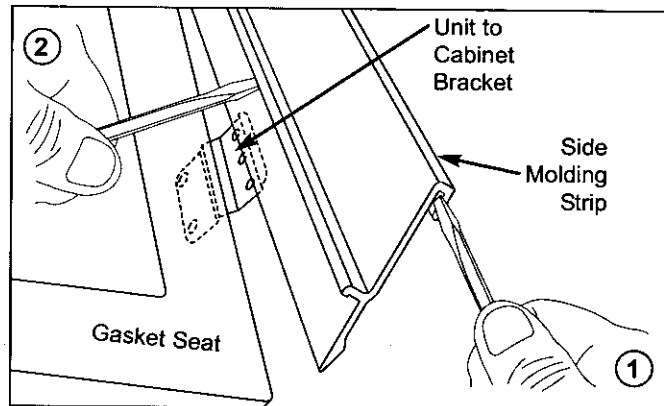

Figure 7-4. Side Molding Removal

Drawer Gasket Removal (All Base Units)

An extruded dart at the back of the drawer gaskets is pressed into retaining channels that are molded into drawer liners.

NOTE: Drawer assemblies must be removed from unit in order to remove and/or install gaskets.

To remove a drawer gasket, simply pull gasket from the retaining channel (See Figure 7-5).

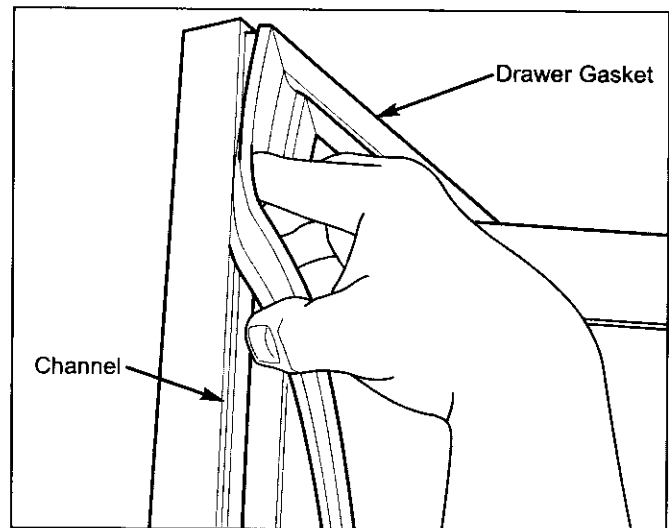

Figure 7-5. Gasket Removal

INTERIOR COSMETIC AND MECHANICAL COMPONENTS

Control Panel Assembly Removal (All Base Units)

The control panel assembly is attached inside top drawer assembly with three screws.

To remove control panel assembly (See Figure 7-6):

1. Extract screws
2. Disconnect display wire harness from control panel assembly and lift assembly up and out.

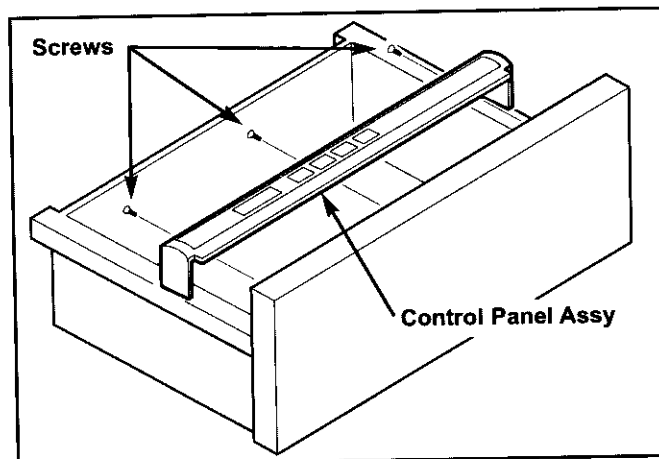

Figure 7-6. Control Panel Assy Removal

Display Wire Harness Removal (All Base Units)

One end of the display wire harness is connected at interior left rear of upper drawer compartment. The middle of the display wire harness is attached to the bottom of upper drawer assembly with tube clamps and snap rivets. The other end is routed up through a channel in the drawer front, held in place under the control panel assembly with cable clamp and screw, and plugged into the control panel assembly.

To remove the display wire harness, the upper drawer assembly must be extracted and the control panel must be removed first, then (See Figure 7-7):

1. Extract screw and cable clamp from top of drawer assembly.
2. Remove cable clamps and snap-rivets from bottom of the drawer assembly by pushing rivet's center push-pin down.
3. Pull wire harness down through channel in drawer front. (See Figure 7-7)

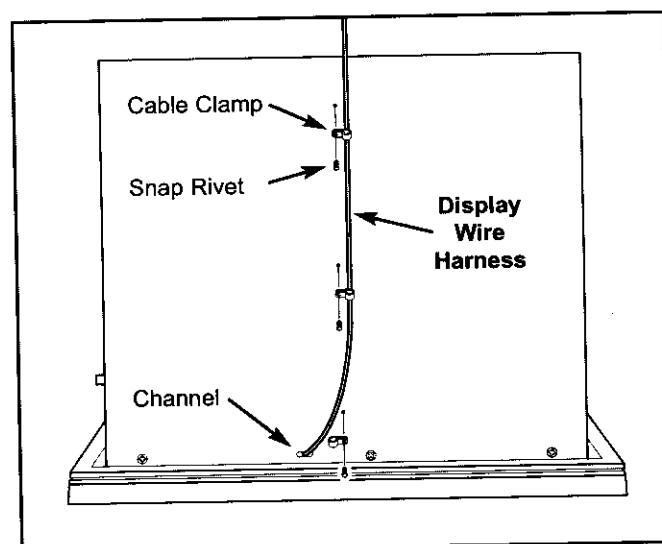

Figure 7-7. Display Wire Harness Removal

Light Bulb and Socket Removal (All Base Units)

Base units have two light bulbs: One in ceiling of top drawer area; One at bottom of divider between drawers. A rubber flange at the back of the socket holds it in a bracket.

Light Bulb Removal (See Figure 7-8):

Turn light bulb counterclockwise to remove it; clockwise to install it.

Light Socket Removal (See Figure 7-8):

Pull light socket from hole in bracket, then disconnect electrical leads.

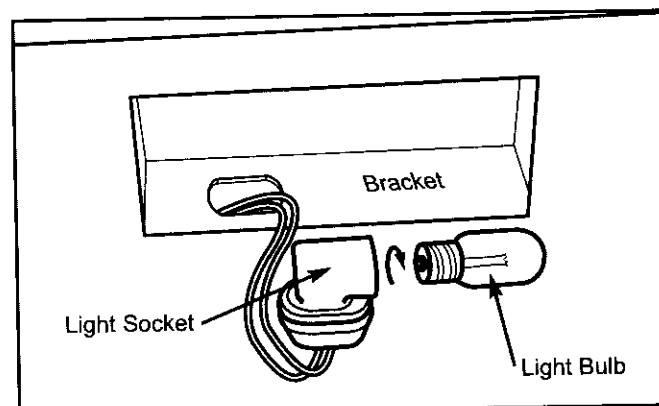

Figure 7-8. Light Bulb / Socket Removal

Mullion Divider Removal (700BC/I-3 Only)

The mullion divider assembly is set between the two drawer areas.

To remove a mullion divider (See Figure 7-9):

1. Remove display wire harness from wire clip.
2. Reach into lower drawer compartment and push divider upwards.

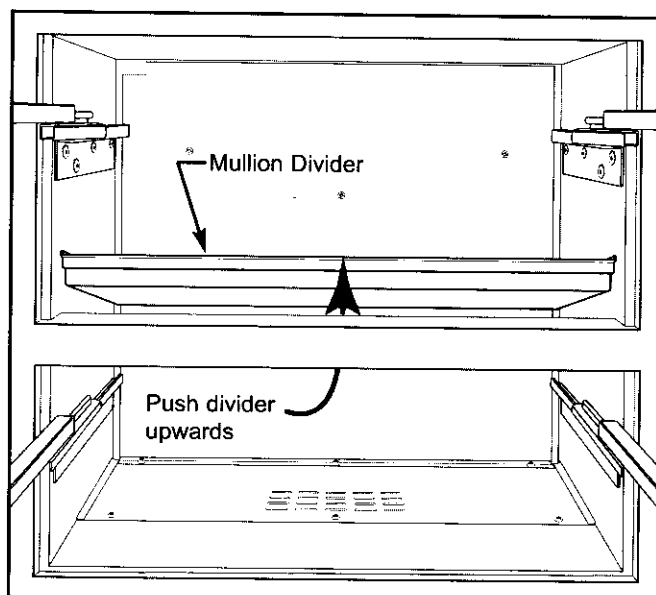

Figure 7-9. Mullion Divider Removal (700BCI-3)

Wire Tray Removal (700BR-3, 700BF/I-3 Only)

The wire tray rests on pegs at the left and at the back right corner of the duct cover. It is set between the two drawer areas.

To remove a wire tray (See Figure 7-10):

1. Remove display wire harness from wire clip.
2. Lift right side of wire tray up, then pull it to the right and out of the compartment.

NOTE: On the model 700BF-3, the screw under the tray that supports the back right corner may need to be loosened prior to step 2 above.

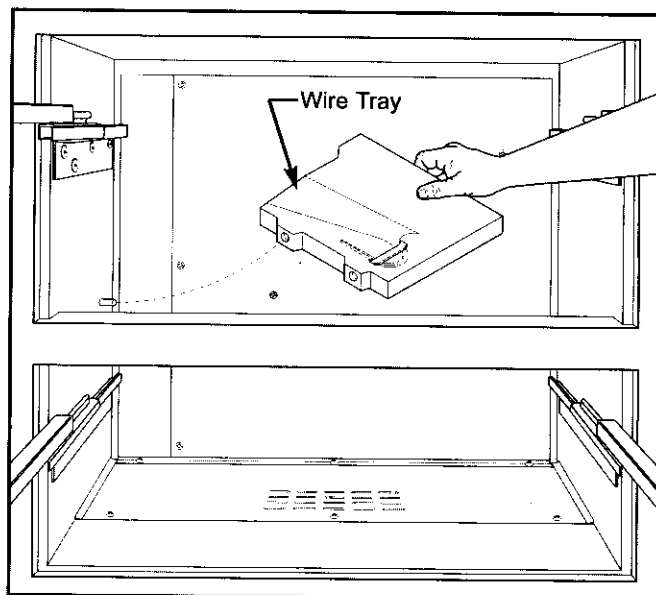

Figure 7-10. Wire Tray Removal (700BFI-3 Shown)

Drawer Closer Assembly Removal (All Base Units)

Drawer closer assemblies are located on the right side wall. Two screws secure each assembly to the wall.

To remove a drawer closer assembly, extract screws that secure drawer closer to wall and pull drawer closer assembly from wall. (See Figure 7-11)

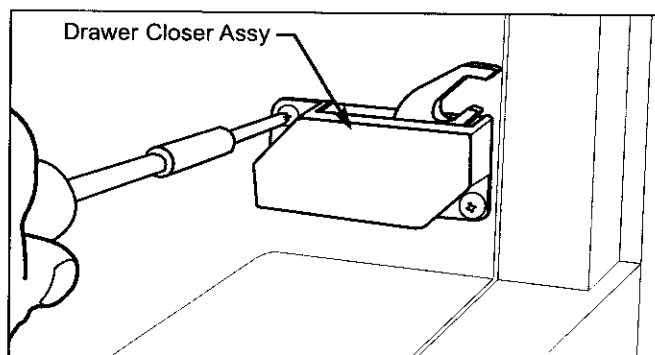

Figure 7-11. Drawer Closer Assembly Removal

Drawer Slide Assembly Removal (All Base Units)

There are four drawer slide assemblies, two on each side wall. Drawer slide assemblies are attached to side walls with Allen-head screws passing through the drawer slide bracket into blind threaded inserts.

To remove a drawer slide assembly, extract mounting screws with a 5/32" Allen-head wrench, and pull drawer slide assembly from wall. (See Figure 7-12)

NOTE: The white thread pins at end of drawer slides are replaceable. Screw pins counterclockwise to remove them. (See Figure 7-12)

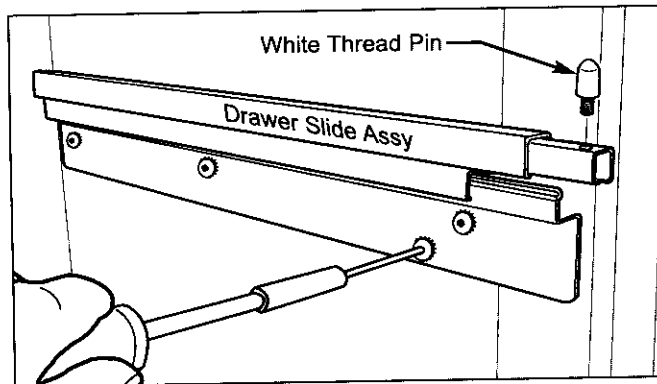
Figure 7-12. Drawer Slide Assembly & Pin
Refrigerator Fan Baffle and Fan Shroud Removal (700BC/I-3 Only)

Screws pass through the refrigerator fan shroud and baffle into screw grommet/stand-offs and a grounding bracket to secure the shroud and baffle to back wall.

Refrigerator Fan Baffle Removal (See Figure 7-13):

1. Extracting the two mounting screws.
2. Pull baffle forward.

Refrigerator Fan shroud Removal (See Figure 7-13):

1. Extracting all mounting screws.
2. Remove nut from display wire harness Methode connector and pull shroud forward slightly.
3. Remove thermistor from key-hole slot at top
4. Disconnect light switch electrical leads, and pull shroud out.

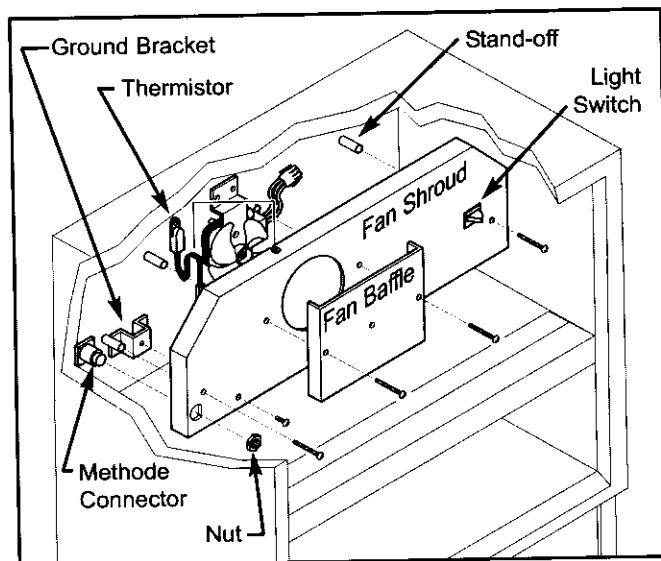
Figure 7-13. 700BC/I-3 Fan Baffle & Shroud
Refrigerator Light Switch Removal (700BC/I-3 Only)

To remove the refrigerator light switch, the fan shroud must be removed first. Then, at back side of fan shroud, depress tabs on each side of switch while pushing switch out. (See Figure 7-14)

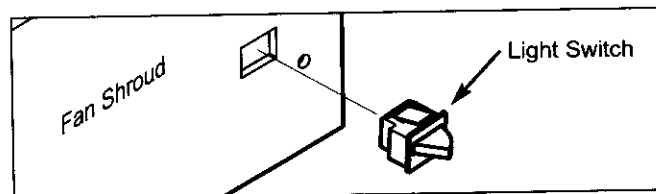
Figure 7-14. 700BC/I-3 Refrigerator Light Switch

Refrigerator Fan Baffle and Cold Plate Removal (700BR-3 Only)

Screws pass through the refrigerator fan shroud into rivnuts that are attached to the refrigerator cold plate.

Behind the baffle, screws pass through the cold plate into screw grommet/stand-offs. A ground wire passes through a hole in the cold plate from behind, and is attached to the front of the cold plate with a screw. Slots in the side flanges of the cold plate fit over pegs at the bottom of each false wall.

Refrigerator Fan Baffle Removal (See Figure 7-15):

1. Extracting baffle mounting screws.
2. Pull baffle forward.

Refrigerator Cold Plate Removal (See Figure 7-15):

1. Extract grounding screw.
2. Extracting cold plate mounting screws.
3. Lean cold plate forward and lift off of locating pegs.

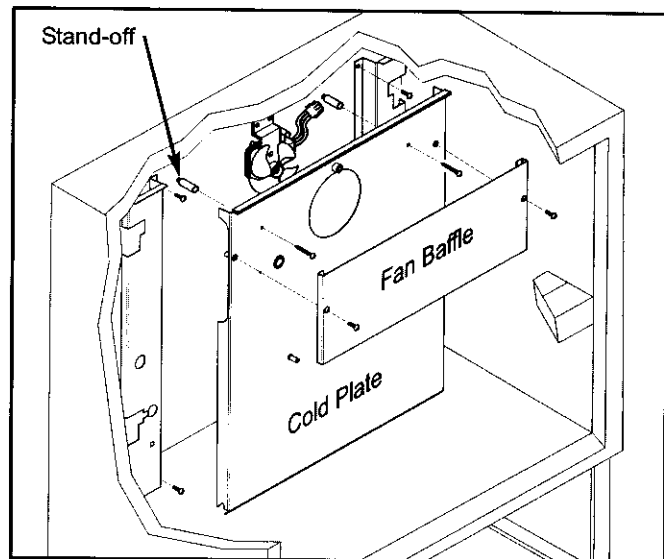

Figure 7-15. 700BR-3 Fan Baffle & Cold Plate

Refrigerator Fan Motor Removal (700BC/I-3, 700BR-3 Only)

The refrigerator fan motor is held to a bracket with screws passing through the motor into screw grommets that are attached to the bracket. The bracket sits behind the motor, and is attached to the back wall with screws.

To remove a refrigerator fan motor (See Figure 7-16):

1. Disconnect motor electrical leads.
2. Extract screw and tube clamp holding motor electrical leads.
3. Extract fan bracket mounting screws and pull the fan motor assembly from the unit.

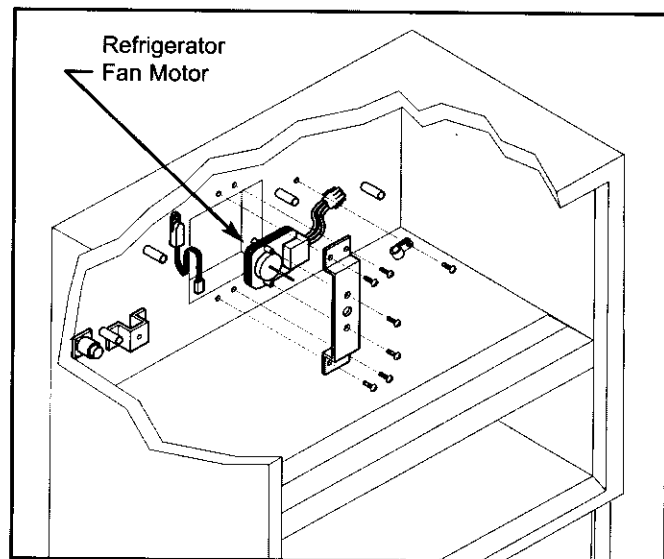

Figure 7-16. Ref Fan Motor (700BC/I-3 Shown)

Refrigerator Compartment Thermistor Removal (700BC/I-3 Only)

The refrigerator compartment thermistor is routed up through a key-hole slot at top of the fan shroud and secured to the back wall with a screw.

To remove the refrigerator compartment thermistor (See Figure 7-17):

1. Extract thermistor mounting screw.
2. Cut thermistor's wire leads six (6) to twelve (12) inches (152 mm to 305 mm) from the back wall, then pull thermistor from compartment.

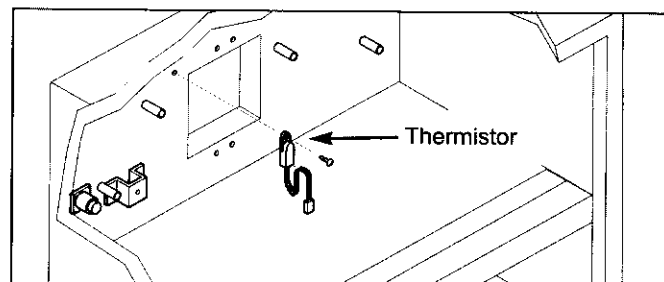

Figure 7-17. 700BC/I-3 Refrigerator Thermistor

Refrigerator Compartment Thermistor Removal (700BR-3 Only)

The refrigerator compartment thermistor passes through a hole in the left false wall from behind, and is attached to the front of the false wall with a screw.

To remove the refrigerator compartment thermistor (See Figure 7-18):

1. Extract thermistor mounting screw.
2. Remove nut from display wire harness Methode connector.
3. Extract the left false wall mounting screws and pull the false wall forward.
4. Cut thermistor's wire leads six (6) to twelve (12) inches (152 mm to 305 mm) from the back wall, then pull thermistor from compartment.

Refrigerator Light Switch Removal (700BR-3 Only)

The refrigerator light switches are inserted into square holes in the right false wall.

To remove a refrigerator light switch (See Figure 7-18):

1. Extract the right false wall mounting screws and pull the false wall forward.
2. Disconnect switch electrical leads.
3. At back side of false wall, depress tabs on each side of switch while pushing switch out.

Refrigerator Evaporator Thermistor Removal (700BR-3 Only)

The refrigerator evaporator thermistor is inserted into the third opening from the top in the evaporator fins left side, extending approximately to the center of the evaporator.

To remove a evaporator thermistor, the left false wall and cold plate must be removed first, then (See Figure 7-19):

1. Pull thermistor from evaporator fins.
2. Cut thermistor's wire leads six (6) to twelve (12) inches from the back wall, then pull thermistor from compartment.

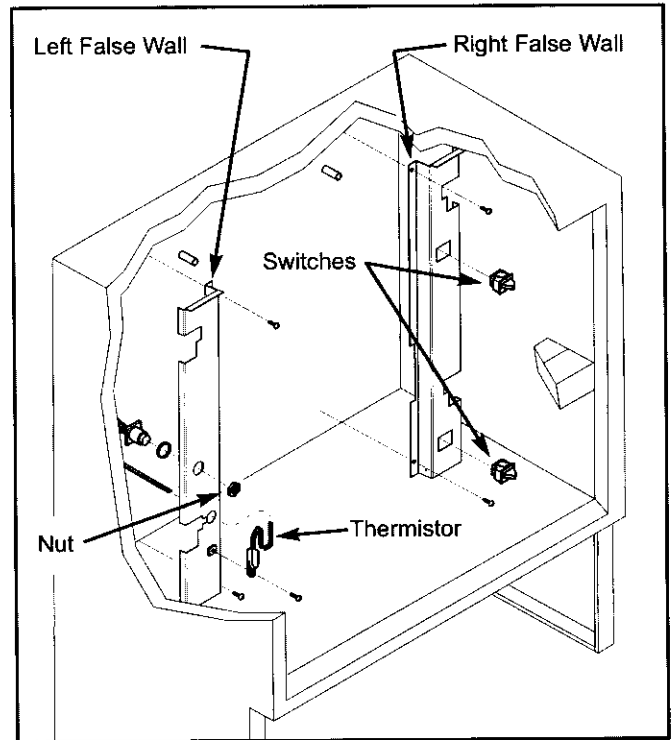

Figure 7-18. 700BR-3 Compartment Thermistor, False Walls and Light Switches

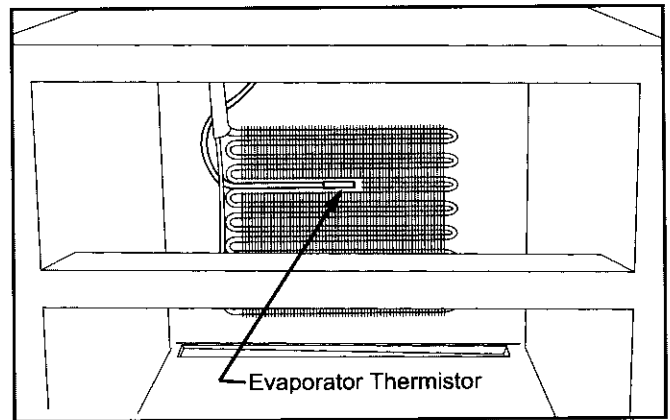

Figure 7-19. 700BR Evaporator Thermistor)

Icemaker Assembly Removal (700BC/I-3, 700BFI-3 Only)

The icemaker assembly is attached at right rear of lower compartment with two screws at top and one screw at bottom that pass through the air duct into screw grommet/stand-offs to hold assembly in place.

To remove the icemaker assembly (See Figure 7-20):

1. Extract bottom icemaker mounting screw.
2. Extract two top icemaker mounting screws.
3. Lower assembly down and disconnect wire harness from head of icemaker, then pull icemaker assembly out.

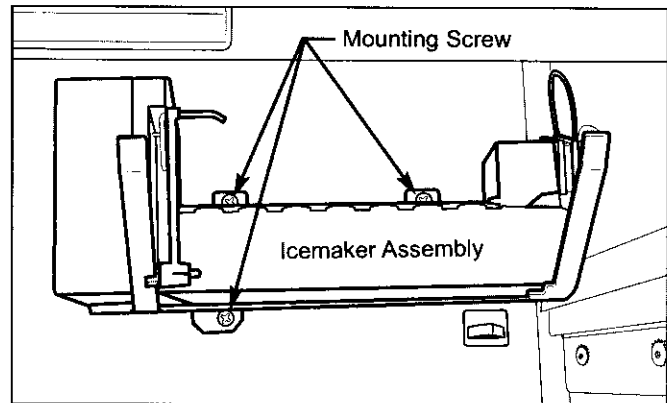

Figure 7-20. Icemaker Removal (700BCI-3/700BFI-3)

Sump Cover Removal (700BC/I-3, 700BFI-3 Only)

The sump cover assembly is held in place with three screws at front that secure it to the floor of the unit. At the rear, three screws pass through the cover into a flange at the bottom of the rear duct.

To remove the sump cover assembly (See Figure 7-21):

1. If icemaker is present, remove it first.
2. Extract screws at front and back of sump cover assembly.
3. Slide sump cover assembly forward and lift up.

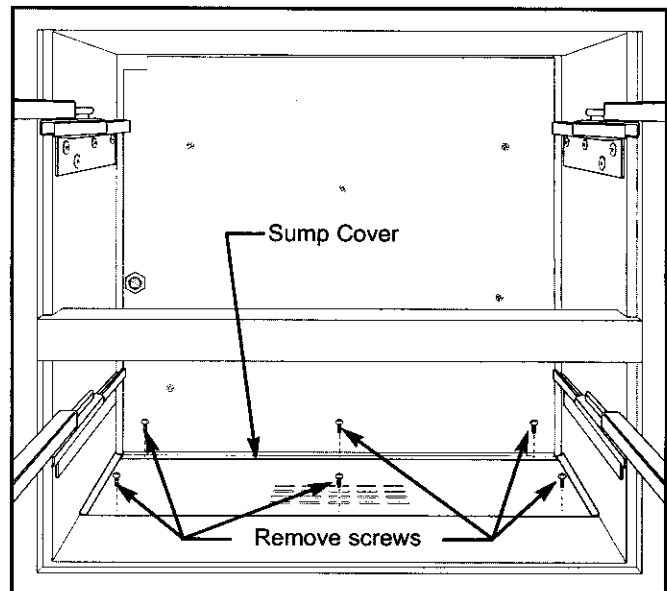

Figure 7-21. Sump Cover (700BCI-3/700BFI-3)

Lower Air Duct Removal (700BC/I-3 Only)

Screws pass through the lower air duct into screw grommet/stand-offs and a grounding bracket to secure the duct to the back wall.

NOTE: Both lower drawer slides must be removed first.

To remove the lower air duct (See Figure 7-22):

1. Extract all lower air duct mounting screws.
2. Pull duct forward slightly.
3. Pull icemaker wire leads from key-hole slot at right.
4. Disconnect light switch and icemaker switch electrical leads, and pull duct out.

Air Baffle Control Assembly Removal (700BC/I-3 Only)

The air baffle control sets in a recessed area of the baffle mount and a piece of tape holds the baffle control in place. Holes in the baffle mount fit over screw grommet/stand-offs in the back wall and when the lower air duct is installed, it captivates the air baffle assembly.

To remove the air baffle control assembly (See Figure 7-22):

1. Remove lower air duct.
2. Unplug the wire leads from the baffle control.
3. Pull air baffle control assembly off of screw grommet/stand-offs.

Freezer Compartment Thermistor Removal (700BC/I-3 Only)

The freezer compartment thermistor is secured to the back wall with a screw.

To remove the freezer compartment thermistor, the lower air duct will need to be removed first, then (See Figure 7-22):

1. Extract thermistor mounting screw.
2. Cut thermistor's wire leads six (6) to twelve (12) inches (152 mm to 305 mm) from the back wall, then pull thermistor from compartment.

Freezer Light Switch and Icemaker Switch Removal (700BC/I-3 Only)

To remove the freezer light switch or icemaker switch, the lower air duct must be removed first. Then, at back side of air duct, depress tabs on each side of switch while pushing switch out. (See Figure 7-23)

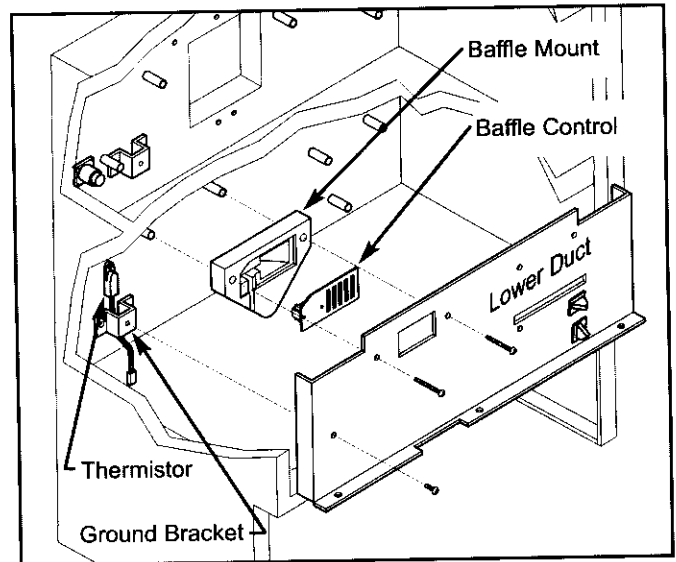

Figure 7-22. 700BC/I-3 Lower Duct, Baffle Control Assembly and Freezer Compartment Thermistor

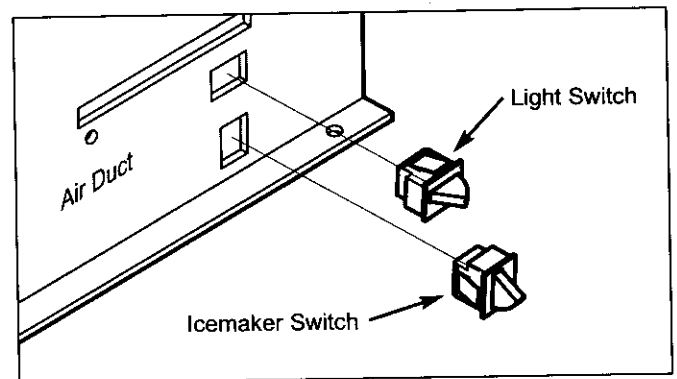

Figure 7-23. 700BC/I-3 Fre Light & IM Switches

Freezer Light Switches and Icemaker Switch Removal (700BF/I-3 Only)

The light switches and fan switch are inserted into square holes in the main air duct.

NOTE: *The sump cover assembly must be removed first.*

To remove a switch (See Figure 7-24):

1. Extract the main air duct mounting screws and pull duct to the left, then forward.
2. Disconnect switch electrical leads.
3. **At back side of duct, depress tabs on each side of switch while pushing switch out.**

Freezer Compartment Thermistor Removal (700BF/I-3 Only)

The freezer compartment thermistor passes through a hole in the left air duct from behind, and is attached to the left wall of the compartment with a screw.

To remove the freezer compartment thermistor (See Figure 7-24):

1. Extract thermistor mounting screw.
2. Remove nut from display wire harness Methode connector.
3. Extract the left air duct mounting screws and pull the duct forward.
4. Cut thermistor's wire leads six (6) to twelve (12) inches (152 mm to 305 mm) from the back wall, then pull thermistor from compartment.

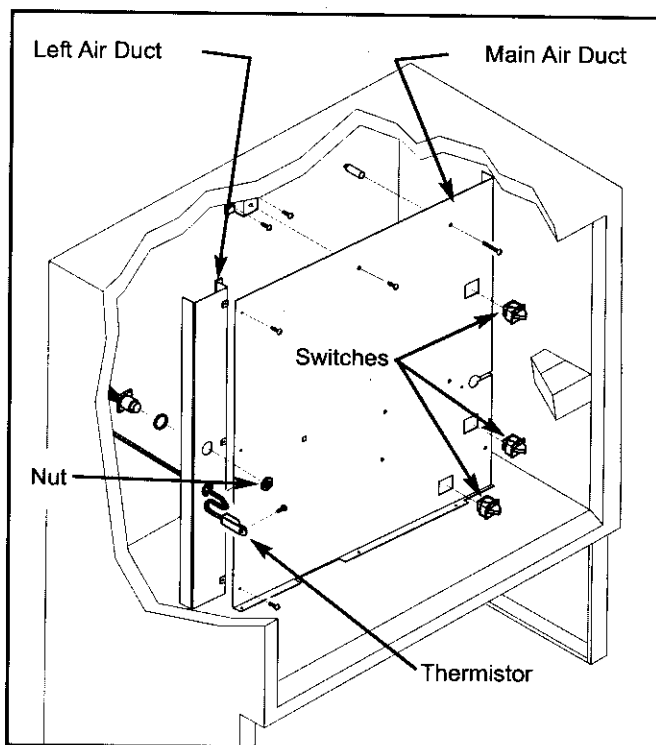

Figure 7-24. 700BF/I-3 Compartment Thermistor, Air Ducts and Light & Fan Switches

**Evaporator Thermistor Removal
(700BC/I-3, 700BFI-3 Only)**

A cable tie holds the evaporator thermistor to the third elbow down on the right side of the evaporator.

To remove the evaporator thermistor (See Figure 7-25):

1. Cut cable tie.
2. Cut thermistor wire leads, and lift the thermistor out of the sump area.

NOTE: There may be a Y-harness between the thermistor electrical connections, with wires exiting through the heat exchanger hole in sump. This is for factory test purposes and can be removed or bypassed.

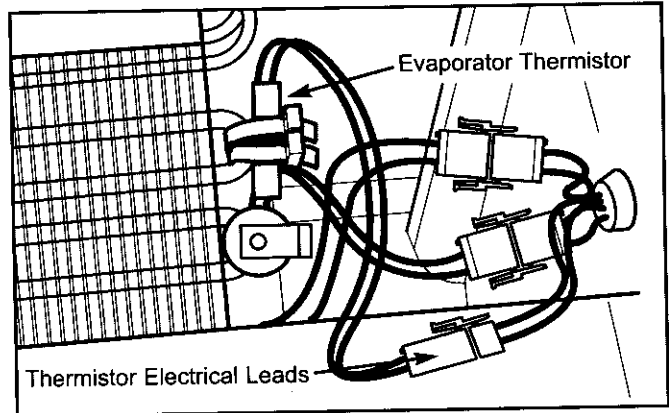

**Figure 7-25.
700BCI-3 & 700BFI-3 Evaporator Thermistor**

**Defrost Terminator Removal
(700BC/I-3, 700BF/I-3 Only)**

The defrost terminator is attached to the sixth elbow down on the right side of the evaporator.

To remove the defrost terminator (See Figure 7-26):

1. Disconnect terminator electrical leads.
2. Disengage terminator clip from return elbow and lift terminator out of the sump area.

NOTE: When reinstalling defrost terminator, it must be attached to the the same elbow (sixth down) it was removed from. Failure to do so could cause shortened defrost times which will lead to incomplete defrost.

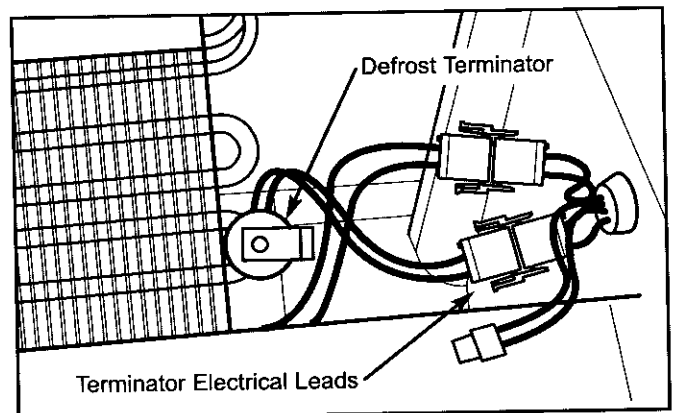

**Figure 7-26.
700BCI-3 & 700BFI-3 Defrost Terminator Removal**

**Defrost Heater Removal
(700BC/I-3, 700BF/I-3 Only)**

The defrost heater is pressed into evaporator fins at front. Heater clips then hook from one evaporator tube to another, over heater.

To remove the defrost heater (See Figure 7-27):

1. Disconnect heater electrical leads.
2. Disengage heater clips from evaporator using needle-nose pliers.
3. Pull heater from evaporator fins, and lift heater out of the sump area.

NOTE: When installing heater, make sure it is positioned as far left as possible. Installing heater too close to terminator could cause shortened defrost times which will lead to incomplete defrost.

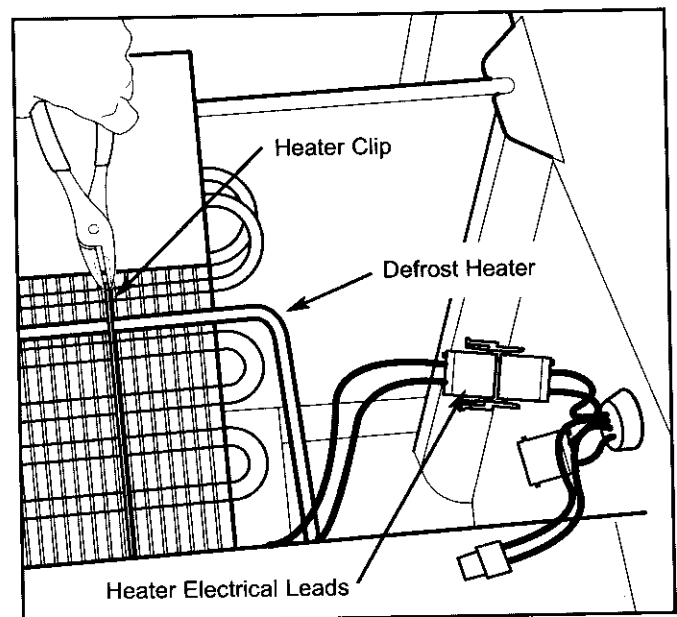

**Figure 7-27.
700BCI-3 & 700BFI-3 Defrost Heater Removal**

Control Board Assembly Removal (700BC/I-3, 700BFI-3 Only)

The control board assembly sets in the right side of sump. Flanges and grooves on the sides of control board assembly help to locate it.

To remove the control board assembly (See Figure 7-28):

1. First remove rear duct(s).
2. Unplug all electrical leads from the control board assembly and lift the assembly from the sump.

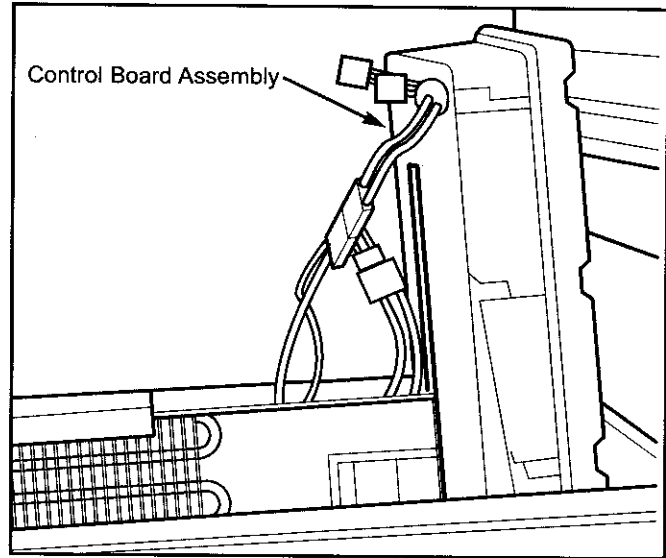

Figure 7-28.
700BCI-3 & 700BFI-3 Control Board Assembly

Evaporator Fan Assembly Removal (700BC/I-3, 700BFI-3 Only)

The side flanges of the evaporator fan assembly slide down into grooves in the fan shroud. The bottom of the evaporator fan assembly sits on a flange at the bottom of the fan shroud. (See Figure 7-29)

To remove the evaporator fan assembly (See Figure 7-30):

1. First remove rear duct(s).
2. Unplug fan assembly electrical leads and lift assembly up out of the grooves in the fan shroud.

NOTE: Do not attempt to remove the fan assembly without removing the back duct. Doing so will deform the back duct and cause air leaks around the air baffle.

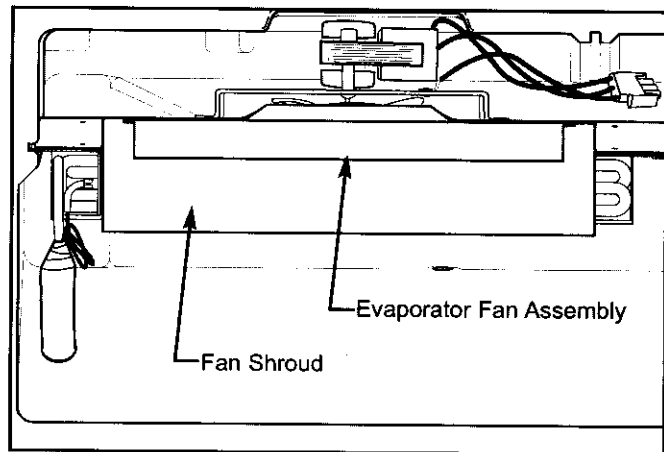

Figure 7-29. Top View of 700BCI-3 & 700BFI-3 Evaporator Fan Assembly in Sump

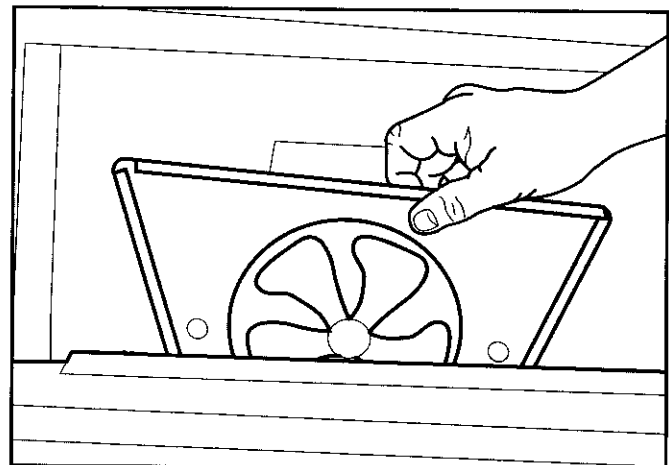

Figure 7-30.
700BCI-3 & 700BFI-3 Evaporator Fan Assembly

COMPRESSOR AREA MECHANICAL COMPONENTS**Main Control Board (700BR-3 Only)**

The main control board is attached to the inside of the control housing assembly with screws. The control housing assembly is attached to the unit tray at the front right corner.

To remove the main control board, the kickplate/grill will need to be removed first. Now, extract the two screws that secure the unit tray to the unit and slide the tray out (See Figure 7-31), then (See Figure 7-32).

1. Extract screws from control housing cover.
2. Disconnect all electrical lads from main control board.
3. Extract screws which are holding control board in control housing and lift control board out of housing.

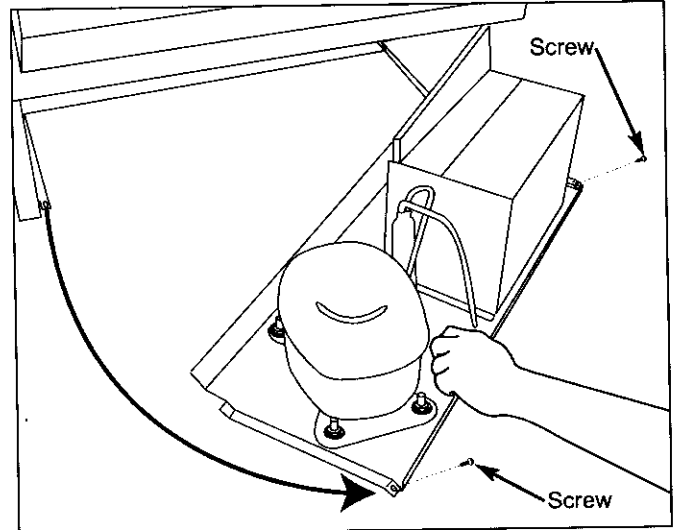
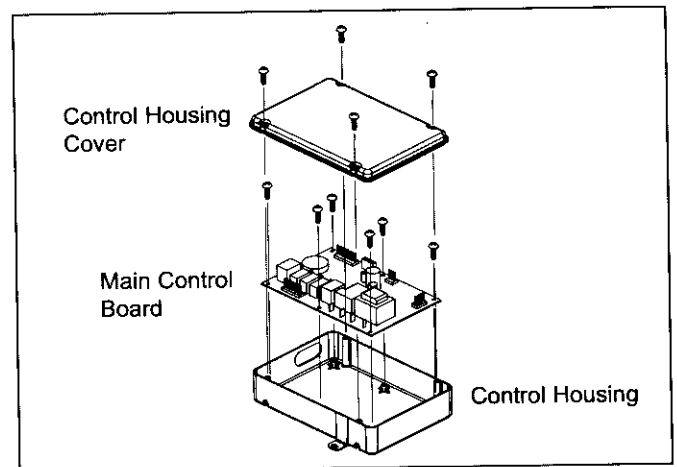
**Figure 7-31. Sliding Unit Tray Out****Figure 7-32. 700BR-3 Main Control Board**

Icemaker Water Valve Removal (700BCI-3, 700BFI-3 Only, Prior to Serial #2421189)

The icemaker water valve assembly is attached to the valve bracket, located on right side of compressor area. A screw passing through a key-hole slot in valve assembly secures the valve to the valve bracket.

NOTE: Before accessing the icemaker water valve, turn off the water supply to the unit.

To remove the water valve, the kickplate/grill will need to be removed first. Then, extract the two screws that secure the unit tray to the unit and slide the tray out (See Figure 7-33), then (See Figures 7-34 and 7-35).

1. With a wrench, disconnect brass compression fitting which holds water supply line to water inlet stub.
2. With a Phillips screwdriver, loosen screw that secures valve assembly to valve bracket.
3. Grab water inlet stub and lift up so head of screw lines up with large section of key-hole slot.
4. Pull valve assembly forward until screw clears key-hole slot, then lower assembly down until valve body clears valve bracket and pull assembly out from compressor area.
5. Unplug valve electrical leads.
6. Disconnect outlet tube plastic compression fitting with a wrench, and lift water valve up.

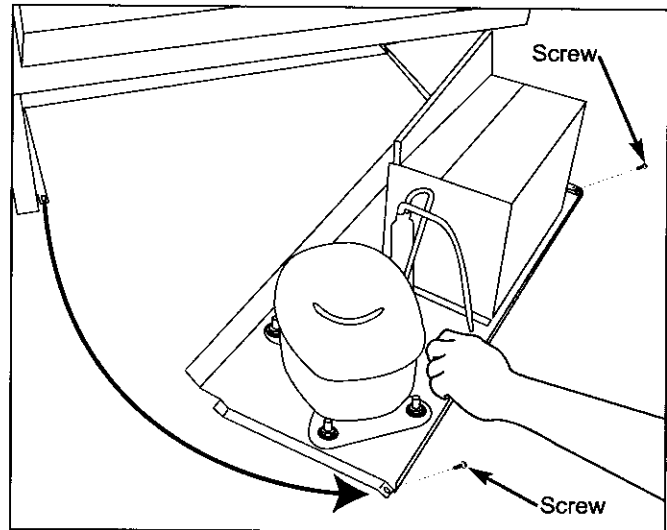

Figure 7-33. Sliding Unit Tray Out

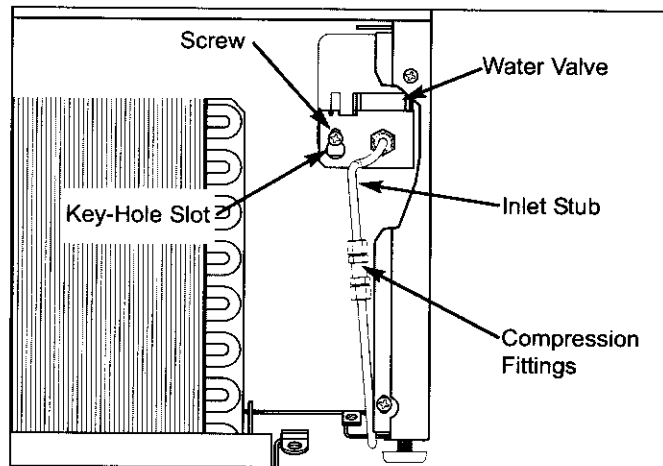

Figure 7-34. Water Valve Removal

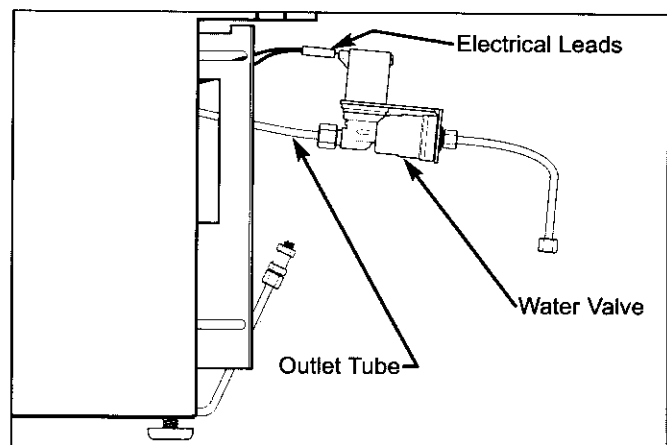

Figure 7-35. Water Valve Removal

**Icemaker Water Valve Removal
(700BCI-3, 700BFI-3 Only, Starting with Serial #2421189)**

The icemaker water valve assembly is located at the right side of the compressor area, and is attached to the valve bracket with screws.

NOTE: Before accessing the icemaker water valve, turn off the water supply to the unit.

To remove the water valve, the kickplate/grill will need to be removed first. Then, extract the two screws that secure the unit tray to the unit and slide the tray out (See Figure 7-36), then (See Figure 7-37).

1. Disconnect inlet water tube from the valve inlet by pushing collar around tube toward valve, while pulling inlet water tube away from valve.
2. With a Phillips screwdriver, remove screws from valve bracket.
3. Lower valve and pull forward.
4. Unplug valve electrical leads.
5. Disconnect outlet tube from the valve outlet by pushing collar around tube toward valve, while pulling outlet water tube away from valve.

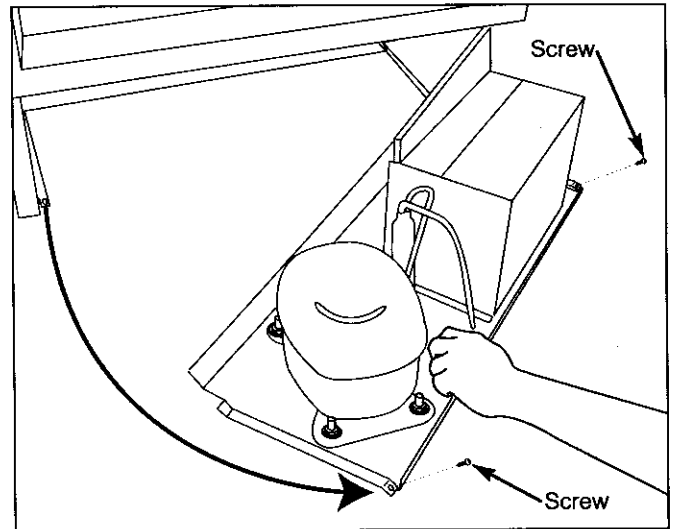
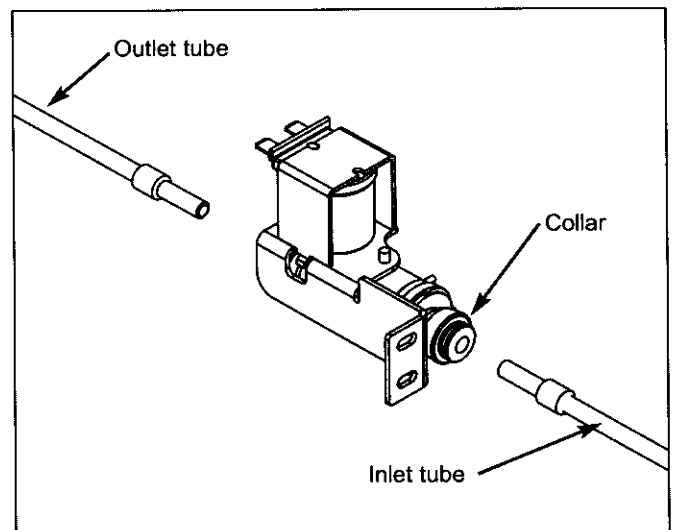
**Figure 7-36. Sliding Unit Tray Out****Figure 7-37. Water Valve Removal**

Condenser Fan Assembly Removal (All Base Units)

The condenser fan shroud sets on pegs protruding from unit tray, with two screws at top securing it to the condenser. The condenser fan is mounted to the condenser fan shroud with three fan mounting brackets that are hooked into grommets holes in the fan shroud. Screws passing through these brackets secure the fan motor to the brackets. The condenser fan blade is held onto the fan motor shaft with a nut.

To remove the condenser fan components, the kick-plate/grill will need to be removed first. Then, extract the two screws that secure the unit tray to the unit and slide the tray out (See Figure 7-38).

NOTE: It may be necessary to disconnect compressor electrical leads in order to pull tray out far enough to access condenser fan assembly.

Condenser Fan Assembly Removal (See Figure 7-39):

1. Disconnect condenser fan motor electrical leads.
2. Extract the screws at top of fan shroud and lift shroud and motor up off pegs at the bottom.

Condenser Fan Motor Removal (See Figure 7-40):

1. Extract screws securing motor to brackets.
2. Unhook brackets from grommets holes in condenser fan shroud.

Condenser Fan Blade Removal (See Figure 7-40):

1. Grab fan blade and motor.
2. Turning nut counterclockwise.
3. Pull blade from motor shaft.

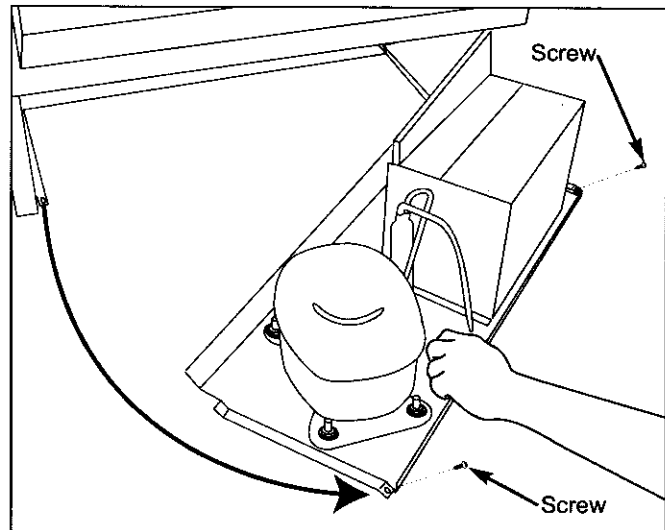

Figure 7-38. Sliding Unit Tray Out

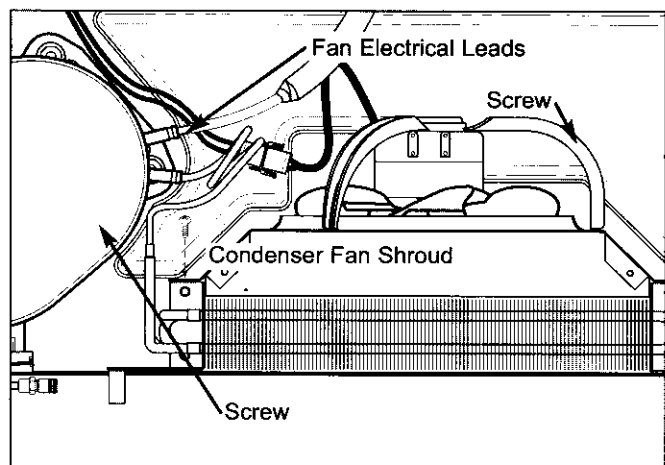

Figure 7-39. Condenser Fan Shroud Removal

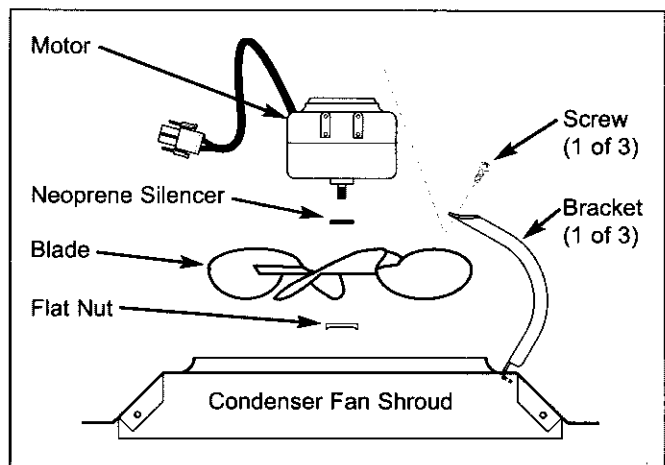

Figure 7-40. Condenser Fan Assembly

**Drain Tube Heater Removal
(700BC/I-3, 700BF/I-3 Only)**

The electrical connections for the drain tube heater are located at the back of the compressor area with the braided heater leads entering the sump drain tube from the compressor area.

To remove the drain tube heater, the kickplate/grill will need to be removed first. Then, extract the two screws that secure the unit tray to the unit and slide the tray out (See Figure 7-41).

NOTE: It may be necessary to disconnect the compressor electrical leads in order to pull the tray out far enough to access the drain tube heater.

Unplug the drain tube heater electrical leads and pull the heater from the drain tube (See Figure 7-42).

NOTE: When installing the replacement drain tube heater, push the braided heater leads into the sump drain tube until splices are 2-1/2" from drain tube outlet (See Figure 7-42). Also, it is recommended to remove the sump cover to make sure the drain tube heater has slid under the evaporator.

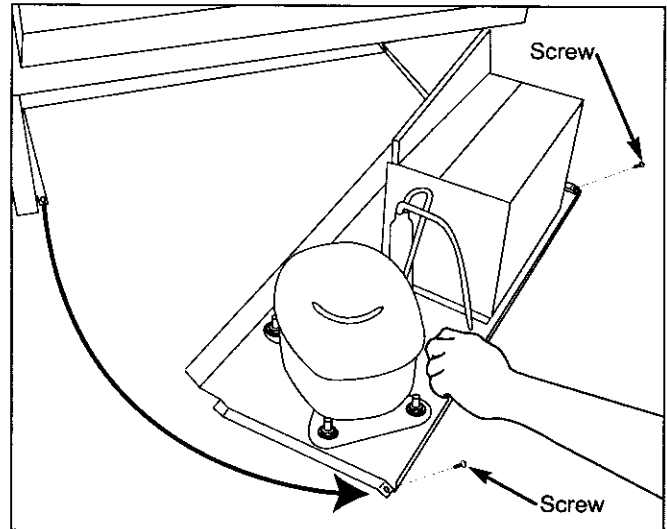
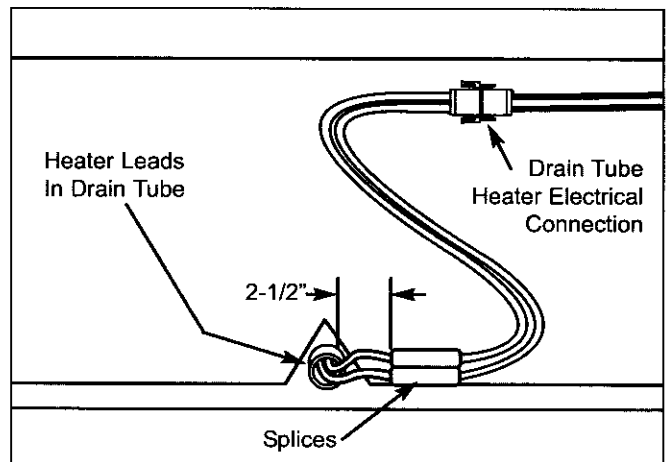
**Figure 7-41. Sliding Unit Tray Out****Figure 7-42. Drain Tube Heater in Compressor Area**

SEALED SYSTEM COMPONENTS

NOTE: When entering the sealed system, always use solder-on process valves. Do **NOT** use bolt-on process valves as they are prone to leak.

NOTE: Whenever servicing the sealed system, the high-side filter-drier must be replaced.

High-Side Filter-Drier Removal (All Base Units)

The high-side filter-drier is located to the right of the condenser and is attached to the condenser outlet tube with a cable tie.

NOTE: Before attempting to remove a filter drier, evacuate refrigerant from sealed system.

To remove the filter-drier, the kickplate/grill will need to be removed first. Then, extract the two screws that secure the unit tray to the unit and slide the tray out (See Figure 7-43).

NOTE: It may be necessary to disconnect the compressor electrical leads in order to pull the tray out far enough to access the filter-driers.

To Remove the filter drier (See Figure 7-44):

1. Cut cable tie securing filter-drier to bracket, or condenser outlet tube.
2. With the edge of a file, score a line around capillary tube approximately one inch (25 mm) from filter-drier outlet
3. Fatigue capillary tube at line just scored until it separates.
4. With a tube cutter, cut inlet tube approximately one inch (25 mm) from filter-drier.

NOTE: Sweating the joints apart is not recommended as this may induce moisture into the sealed system and could cause a solder restriction in the capillary tube.

NOTE: Check the end of the remaining capillary tube for internal burrs. If burrs exist, rescore a line around the capillary tube approximately one inch from the end and fatigue the capillary tube at this new line until it separates.

NOTE: When installing the replacement filter-drier, insert the capillary tube until it touches the screen, then pull the capillary tube approximately 3/8" away from the screen before brazing (See Figure 7-45). When installing a new filter-drier, be sure to thoroughly clean the tubing before brazing.

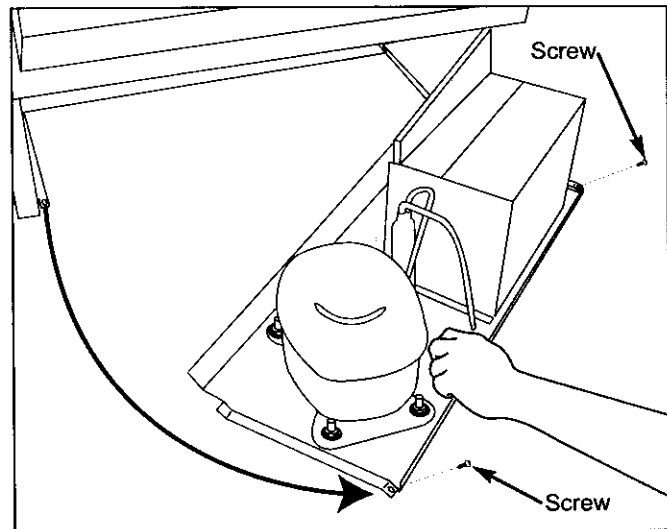

Figure 7-43. Sliding Unit Tray Out

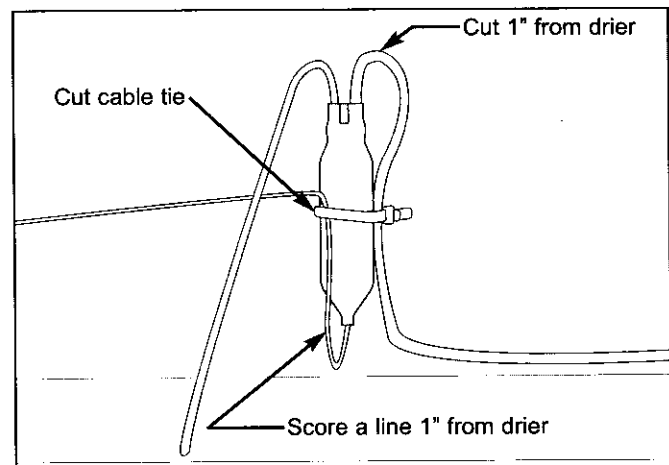

Figure 7-44. Filter-Drier Removal

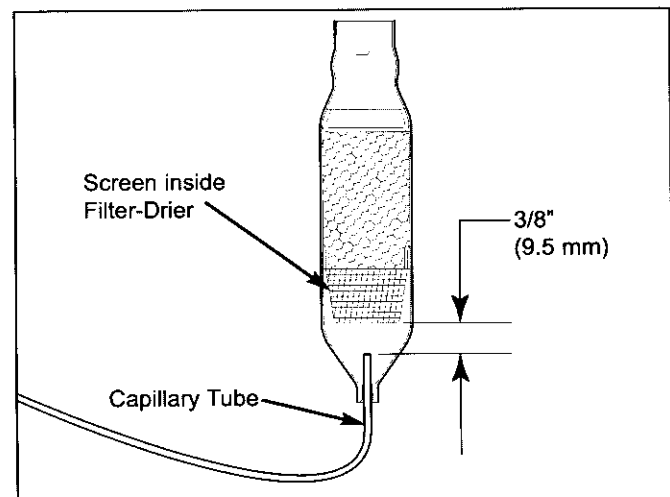

Figure 7-45. Filter-Drier Cut-Away View

Compressor Removal (All Base Units)

The compressor has four rubber compressor grommets inserted into its base. Cylindrical metal spacers are placed over threaded studs that are press fit to the unit tray. The compressor grommets fit over the spacers and a washer sets on top of the grommet and spacer. A nut is then installed on the threaded stud and tightened down on the washer and spacer.

NOTE: Before attempting to remove a compressor, evacuate the refrigerant from the sealed system.

To remove the compressor, the kickplate/grill will need to be removed first. Then, extract the two screws that secure the unit tray to the unit and slide the tray out (See Figure 7-46), then (See Figures 7-48 and 7-48).

1. Use a flat-blade screwdriver to remove compressor electrical cover
2. Disconnect electrical leads from compressor.
3. Cut compressor inlet and outlet tubing with a tube cutter, approximately one inch (25 mm) from compressor ports.
4. Extract nuts and washers from threaded studs.
5. Lift compressor off of threaded studs.

NOTE: Sweating the joints apart is not recommended as this may induce moisture into the sealed system.

NOTE: The high-side filter-drier must be replaced whenever servicing the sealed system.

NOTE: When installing a compressor, be sure to thoroughly clean the tubing before brazing.

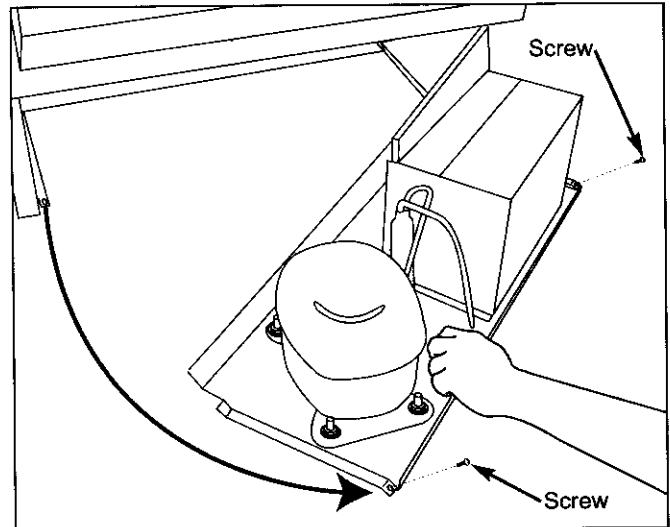

Figure 7-46. Sliding Unit Tray Out

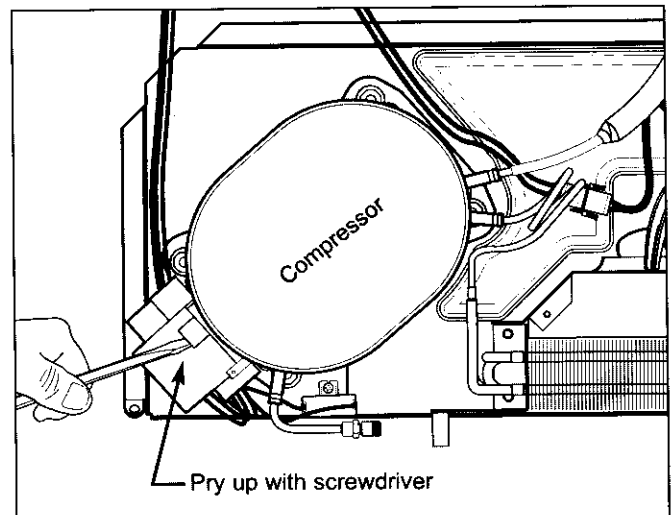

Figure 7-47. Removing Compressor Electrical Cap

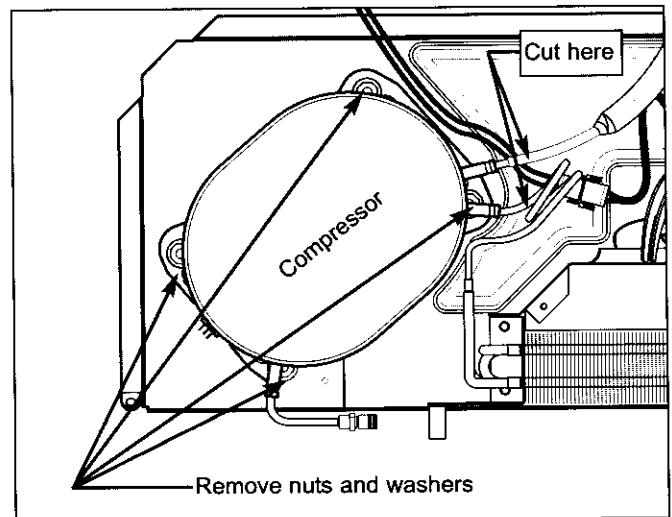

Figure 7-48. Compressor Removal

Condenser Removal (All Base Units)

The condenser is secured to the unit tray by four rivets that pass up through the unit tray into the condenser side brackets.

NOTE: Before attempting to remove the condenser, evacuate the refrigerant from the sealed system.

To remove the condenser, the kickplate/grill will need to be removed first. Then, extract the two screws that secure the unit tray to the unit and slide the tray out (See Figure 7-49).

NOTE: It will be necessary to disconnect the compressor electrical leads in order to pull the tray out far enough to remove the condenser.

To Remove the condenser (See Figure 7-50):

1. Cut condenser inlet and outlet tubes to and from the condenser, approximately one inch (25 mm) from weld joints.
2. Prop front of unit tray up.
3. Drill out rivets securing condenser to tray.

NOTE: Sweating the joints apart is not recommended as this may induce moisture into the sealed system.

NOTE: The high-side filter-drier must be replaced whenever replacing the condenser.

NOTE: When installing the replacement condenser, be sure to thoroughly clean the tubing before brazing.

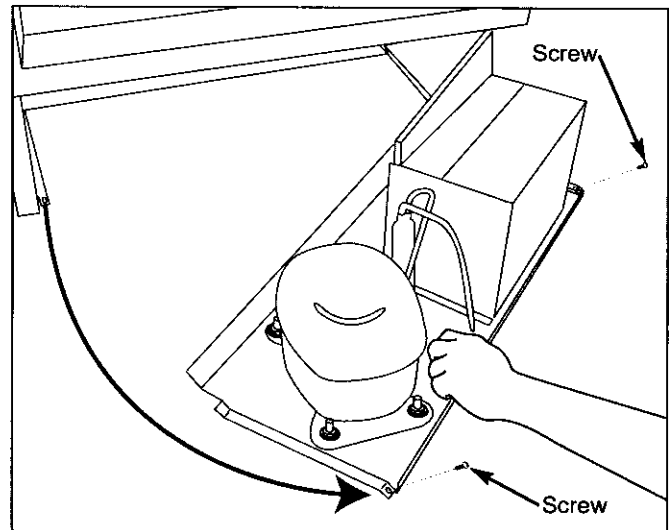

Figure 7-49. Sliding Unit Tray Out

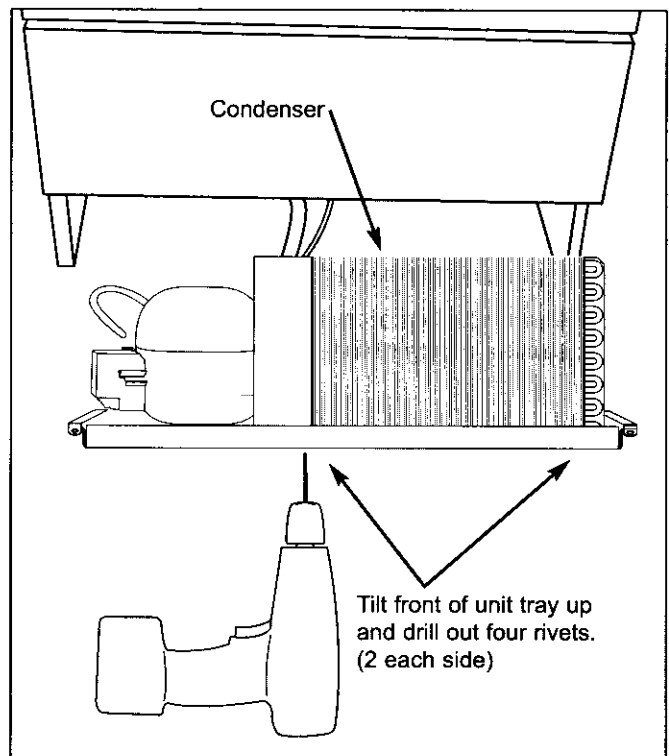

Figure 7-50. Condenser Removal

Evaporator / Heat Exchanger Assembly Removal (700BC/I-3, 700BF/I-3 Only)

The evaporator / heat exchanger assembly was installed into the unit by inserting the heat exchanger down through the hole at top left front of sump. As the heat exchanger is fed through the hole, the side brackets of the evaporator slide down into channels in sump and control board enclosure. Tubing insulation is then installed over the heat exchanger before it is coiled and attached to the back of unit tray area with a P-clamp and screw. Then, the heat exchanger is attached to the compressor and filter-drier.

NOTE: Before attempting to remove the evaporator / heat exchanger assembly, evacuate the refrigerant from the sealed system.

To remove the evaporator / heat exchanger assembly, the kickplate/grill will need to be removed first. Then, extract the two screws that secure the unit tray to the unit and slide the tray out (See Figure 7-49).

NOTE: It will be necessary to disconnect the compressor electrical leads in order to pull the tray out far enough to remove the heat exchanger.

To remove the evaporator/heat exchanger assembly (See Figures 7-51, 7-52 and 7-53):

1. Since evaporator/heat exchanger assembly being removed will be scrapped, use a tin snips or similar tool to cut heat exchanger near hole in sump.
2. Disconnect all electrical leads of components attached to evaporator and lift evaporator from sump.

NOTE: There may be a Y-harness between the thermostat electrical connections, with wires exiting through the heat exchanger hole in sump. This is for factory test purposes and can be removed or bypassed.

3. Cut suction line approximately 2" (51 mm) from compressor.
4. Since filter-drier will be replaced, cut drier inlet tube approximately one inch (25 mm) from drier, leaving capillary tube attached.
5. Extract screw holding heat exchanger and P-clamp to rear of unit tray area.
6. Pull heat exchanger down through hole at top left front of sump and out of unit tray area.

NOTE: When installing replacement evaporator / heat exchanger assembly, be sure to thoroughly clean tubing before brazing.

NOTE: After installing replacement evaporator / heat exchanger assembly, apply a bead of silicone around heat exchanger where it exits through hole in sump.

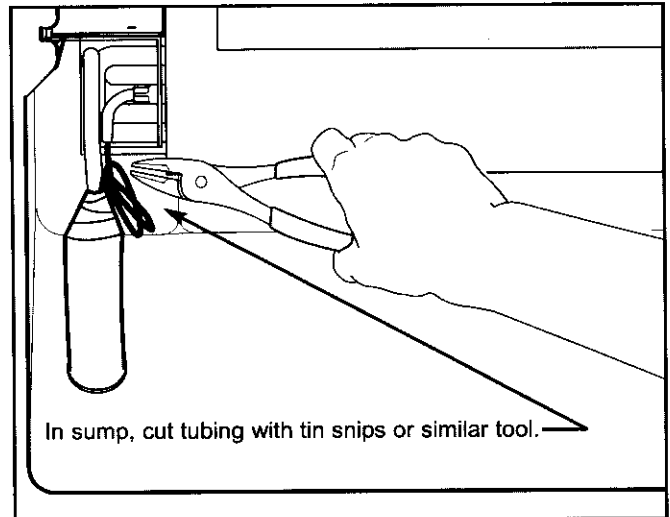

Figure 7-51. Cut Suction & Capillary Tube at Evap.

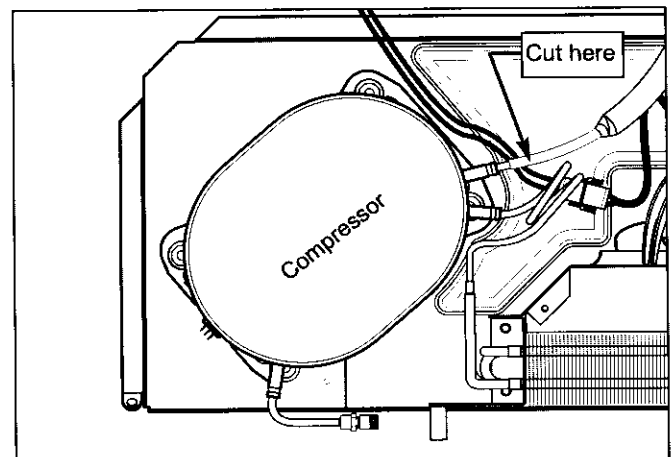

Figure 7-52. Cut Suction line at compressor

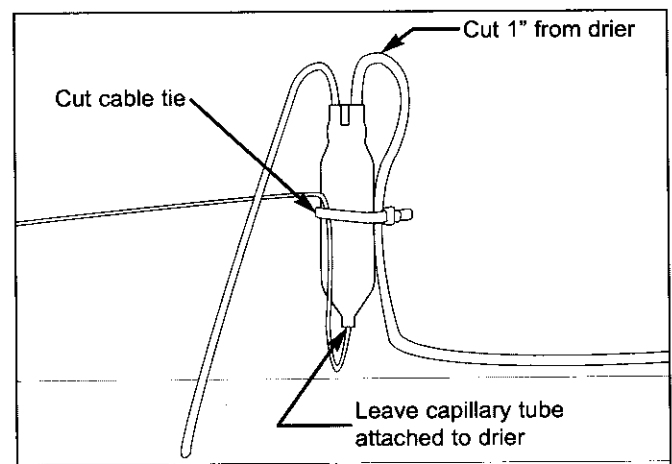

Figure 7-53. Cut Inlet at Filter-Drier

Evaporator Removal (700BR-3 Only)

The evaporator is attached to the rear walls of the compartments with screws.

NOTE: Before attempting to remove the evaporator, evacuate the refrigerant from the sealed system.

To remove the refrigerator evaporator (See Figure 7-54):

1. Extract screws which hold evaporator to rear wall of compartment.
2. Pull and rotate evaporator so heat exchanger is accessible.
3. With a file, score a line around capillary tube, 1" (25 mm) or less from evaporator inlet, then fatigue capillary tube at this line until it separates.
4. With a tube-cutter, cut evaporator outlet 1" (25 mm) or less from suction line connection point.

NOTE: It is not recommended to sweat tubing apart. Doing so will induce moisture into the sealed system.

NOTE: After capillary tube is fatigue until it separates, check tubing for internal burrs. If burrs exist, repeat step 3 above.

NOTE: Sweating the joints apart is not recommended as this may induce moisture into the sealed system and could cause a solder restriction in the capillary tube.

NOTE: When installing replacement evaporator, be sure to thoroughly clean tubing before brazing.

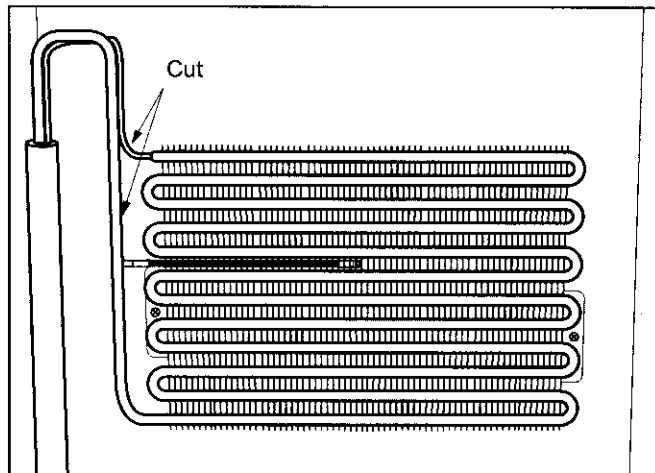

Figure 7-54. 700 BR-3 Refrigerator Evaporator