

361 RFD DOORS

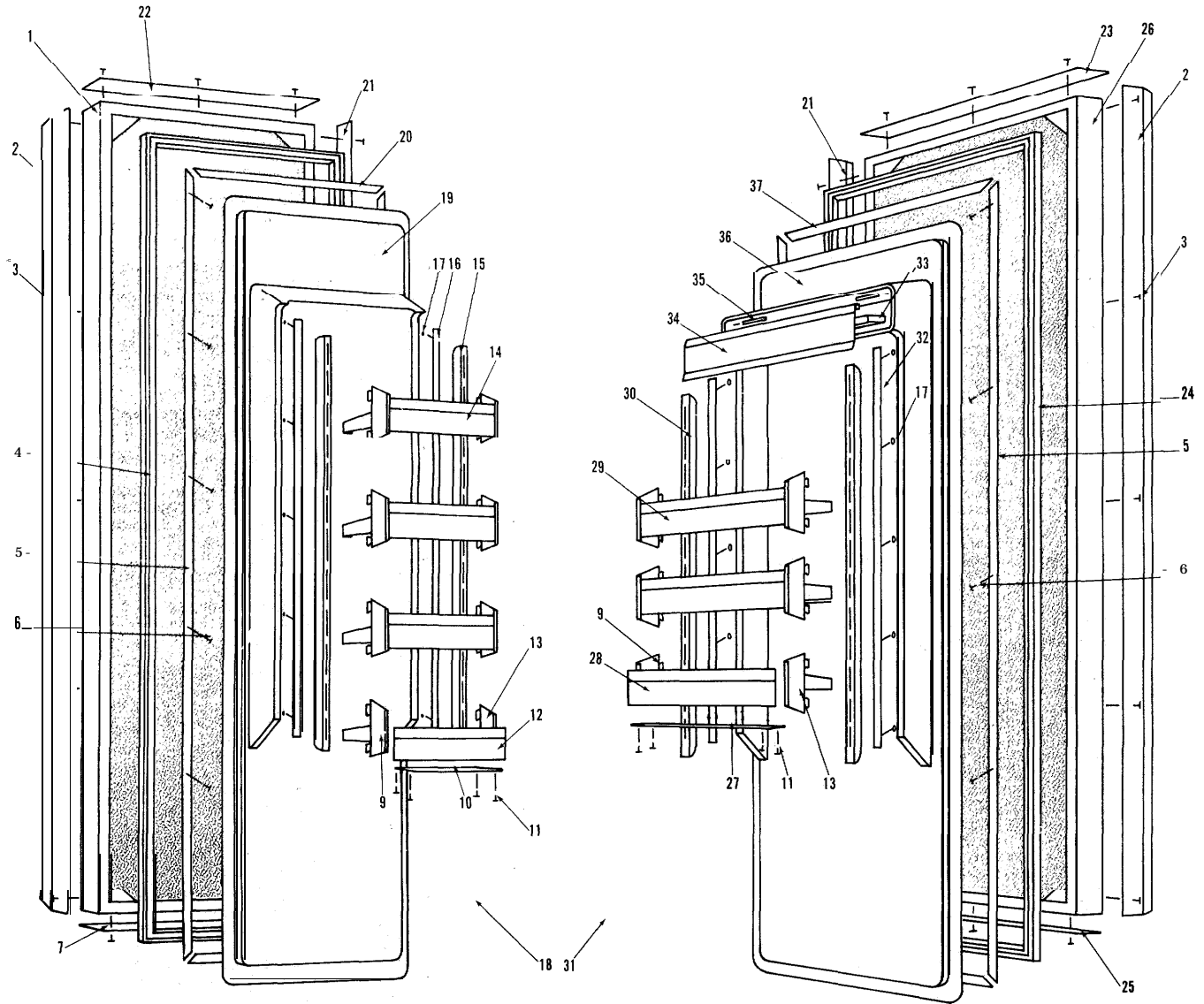

Item #	Part #	Description
1	0-17052-0	Freezer Door Shell
2	2-2126-01	Door Handle, 67-7/8
3	6-20-004-0	Screw, #4-24 x 1/2 Truss Head
4	3-21-013-0	Freezer Door Gasket, 14.563 x 67.375
5	3-42-026-0	Gasket Retainer, Side, 66.875
6	6-20-041-0	Screw, #8 x 1/2 Slot Head Hex
7	2-2182-11	Freezer Bottom Door Trim, 2.07 x14-7/8
9	3-60-022-2	Left Side Door Shelf End Cap
10	2-8066-01	Freezer Door Shelf Tray, 7.19
11	6-20-039-0	Screw, #6 x 3/8 T25 Pan Head
12	2-8059-04	Freezer Door Shelf Guard, 8-7/8
13	3-60-022-1	Right Side Door Shelf End Cap
14	4-33-016-0	Freezer Door Shelf Assembly, 9-5/8
15	2-2145-07	Freezer Door Shelf Ladder, 35-5/16
16	4-15-020-0	Freezer Door Shelf Ladder Holder Assembly, 33.5
17	6-15-032-0	Nut, #8-32 Pal (D0832075)
18	4-13-053-0	Complete Freezer Door Assembly

Item #	Part #	Description
19	0-18221-0	Freezer Door Liner
20	3-42-013-0	Freezer Door Top & Bottom Gasket Retainer, 13.812
21	2-2182-07	Side Door Trim, 2.07 x67-7/8
22	2-2182-10	Freezer Top Door Trim, 2.07 x14-7/8
23	2-2182-08	Refrigerator Top Door Trim, 2.07 x19-3/8
24	3-21-012-0	Refrigerator Door Gasket, 19.063 x 67.375
25	2-2182-09	Refrigerator Bottom Door Trim, 2.07 x19-3/8
26	0-17051-0	Refrigerator Door Shell
27	2-8065-01	Refrigerator Door Shelf Tray, 11.81
28	2-8059-03	Refrigerator Door Shelf Guard, 13-3/8
29	4-33-015-0	Refrigerator Door Shelf Assembly, 14-1/8
30	2-2145-05	Refrigerator Door Shelf Ladder, 35
31	4-13-047-0	Complete Refrigerator Door Assembly
32	4-15-020-0	Refrigerator Door Shelf Ladder Holder Asmb., 33.5
33	3-44-001-0	Butter Dish
34	3-48-032-0	Dairy Door, 4.875 x 13.375
35	3-42-005-0	Butter Door Rod, 3/16 x 2
36	0-18215-0	Refrigerator Door Liner
37	3-42-016-0	Refrigerator Top & Bottom Gasket Retainer, 18.250

361 RFD COSMETIC VIEW

Item #	Part #	Description	Item #	Part #	Description
1	4-28-031-0	Unit Shroud Assembly	60	4-18-057-0	Freezer Basket Assembly, 11-3/16 x 16
2	6-20-023-0	Screw, #8-18 x 1/2 Hex Head	61	3-57-003-0	Leveling Rod
5	0-16454-0	Back Cover & Shroud	62	0-16274-0	Kickplate
6	6-20-023-0	Screw, #8-18 x 1/2 Hex Head	63	2-2210-01	Freezer Basket Handle
7	4-12-028-0	Left Side Main Frame Extrusion	64	6-18-004-0	Pop Rivet, 3/16 x 1/8
8	6-20-021-0	Screw, #8-32 x 1/2 Flat Head	65	3-60-039-0	Freezer Basket Shelf
10	3-57-002-0	Rear Leveling Leg, 3/8-18 x 4	66	3-48-069-0	Crisper Front; Plain, 15.332
11	4-11-003-2	Left Base Assembly	67	3-48-053-0	Crisper Handle
12	3-57-004-0	Front Leveling Leg, 3/8-18 x 1-1/2	68	3-41-025-0	Crisper Basket Only
13	2-8073-02	Freezer Bottom Breaker Strip, 13-1/4		4-18-054-0	Crisper Basket Assembly; Plain, 15.69 x 15.95
14	4-18-062-3	Right Crisper Slide Assembly	69	3-48-071-0	Crisper Front Only (Veg.), 15.332
	4-18-062-4	Left Crisper Slide Assembly		4-18-053-0	Crisper Basket Assembly (Veg.), 15.69 x 15.95
15	6-20-045-0	Screw, #8 x 1 Type AB Flat Head	70	3-21-024-0	Front Crisper Seal, 16.81
16	6-20-044-0	Screw, #10 x 11/16 Type B Flat Head	71	4-15-056-0	Crisper Tray Assembly, 16.81 x 15.50
17	3-42-032-0	Roller	72	3-45-018-0	Christmas Tree Clip
18	6-20-014-0	Screw, #8-15 x 3/8 Truss Head	73	3-48-070-0	Crisper Front Only (Meat), 15.332
19	2-2119-04	Left Side Freezer Cantilever Shelf Ladder, 52-1/16		4-18-052-0	Crisper Basket Assembly (Meat), 15.69 x 15.95
20	2-2119-03	Right Side Freezer Cantilever Shelf Ladder, 52-1/16	74	3-21-024-0	Front Crisper Seal, 16.81
21	0-23206-0	Freezer Duct Cover	75	4-15-051-0	Crisper Glass Assembly, 16.81 x 15.50
22	6-20-032-0	Screw, #8-32 x 1/2 Truss Head	76	4-15-039-0	Crisper Trim Assembly, 25.375
23	3-42-034-0	#8 Nylon Screw Insulator	77	3-42-032-0	Roller
24	6-22-019-0	Plastic Support	78	6-20-044-0	Screw, #10 x 11/16 Type B Flat Head
25	6-22-007-0	Support, .44 x .63 x 1.53	79	3-60-034-0	Freezer Cantilever Shelf, 11-7/8
26	6-20-014-0	Screw, #8-15 x 3/8 Truss Head	80	4-18-056-0	Ice Bucket Assembly
27	2-2215-01	Right Side Refrigerator Cantilever Shelf Ladder	81	3-41-040-0	Ice Bucket Handle
28	2-2215-02	Left Side Refrigerator Cantilever Shelf Ladder	82	3-60-033-0	Refrigerator Cantilever Shelf, 16-3/8
29	6-20-014-0	Screw, #8-15 x 3/8 Truss Head	83	3-45-016-0	U-Clip
30	6-12-020-0	Cable Clip, .22 x .79 x .50	84	4-15-033-0	Refrigerator Diffuser Glass Assembly, 5.25 x 16.938
31	6-16-009-0	Spacer, .20 x .38 x 1.44	85	3-41-015-0	Egg Tray
33	6-20-037-0	Screw, #8-18 x 2 Truss Head	86	4-24-003-0	Grille Assembly, 11 x 36
34	4-18-062-3	Right Crisper Slide Assembly	87	3-58-010-0	Sub-Zero Nameplate
	4-18-062-4	Left Crisper Slide Assembly	88	6-15-014-0	Spring Grip Nut, 1/8
35	6-20-045-0	Screw, #8 x 1 Type AB Flat Head	89	6-20-036-0	Screw, #6-32 x 7/8 Truss Head (Grille Screw)
36	2-8073-04	Refrigerator Bottom Breaker Strip, 17-3/4	90	2-8073-20	Side Breaker Strip, 66-3/8 (Ref., RS; Fzr., L5)
38	6-20-044-0	Screw, #10 x 11/16 Type B Flat Head	91	3-45-016-0	U-Clip
39	3-42-032-0	Roller	92	4-12-023-0	Right Side Main Frame Extrusion
40	6-20-001-0	Screw, #10-12 x 3/4 Pan Head	93	4-15-034-0	Freezer Diffuser Glass Assembly, 6.40 x 12.438
41	4-11-003-1	Right Base Assembly	94	3-54-034-0	Right Side Upper Door Hinge
42	3-55-014-0	1/4-20 Self-Thread Insert		3-54-035-0	Left Side Upper Door Hinge
43	3-54-041-0	Bottom Cabinet Hinge	95	3-42-007-0	Hinge Bearing
44	6-24-016-0	Nylon Washer, 5/8 x 380-1/16	96	6-20-007-0	Screw, #4-24 x 3/8 Flat Head
	6-24-017-0	Nylon Washer, 5/8 x 380-3/32	97	6-11-007-0	Bolt, 1/4-20 x 5/8 Hex Head
46	6-11-023-0	Bolt, #10-24 x 1/2 Pan Head	98	0-18256-0	Top Cabinet Hinge
47	6-24-007-0	Lock Washer, 1/4 S.S.	99	6-20-024-0	Screw, #8-32 x 3/8 Phillips Head
48	6-11-016-0	Bolt, 1/4 x 3/4 Hex Head	100	2-2107-01	Main Frame Angle
49	0-18027-1	Right Door Closer Cover	101	2-8073-03	Refrigerator Top Breaker Strip, 17-3/4
	0-18027-2	Left Door Closer Cover	102	2-2195-19	Top Main Frame Extrusion
50	6-24-006-0	Star Washer, 1/4	103	6-20-001-0	Screw, #10-12 x 3/4 Pan Head
51	6-20-001-0	Screw, #10-12 x 3/4 Pan Head	104	6-20-002-0	Screw, #7-16 x 1/2 Pan Head
52	3-54-027-0	Door Closer	105	0-16435-0	Fan Shroud Front Bracket
53	3-54-042-0	Right Side Lower Door Hinge	106	3-45-012-0	Grille Spring, 1/4 x 9-3/8
	3-54-043-0	Left Side Lower Door Hinge	107	6-20-002-0	Screw, #7-16 x 1/2 Pan Head
54	6-11-001-0	Bolt, #10-24 x 1/2 Flat Head (Hinge Screw)	108	4-28-013-0	Compressor Shroud Assembly
55	6-20-007-0	Screw, #4-24 x 3/8 Flat Head (Shipping Screw)	109	2-8073-01	Freezer Top Breaker Strip, 13-1/4
56	6-20-044-0	Screw, #10 x 11/16 Type B Flat Head	110	2-8072-03	Mullion Breaker Strip, 66-3/8 (Fzr., RS; Ref.,
57	3-42-032-0	Roller	111	0-20058-0	Cold Plate Cover
58	3-21-001-0	Gasket, 1/16 x 3/16 x 1/2	112	6-11-007-0	Bolt, 1/4-20 x 5/8 Hex Head
59	6-15-027-0	Nut, #10-24 Acorn	113	3-21-025-0	Rear Crisper Seal
			114	2-2205-01	Crisper Glass Front

361 RFD COSMETIC VIEW

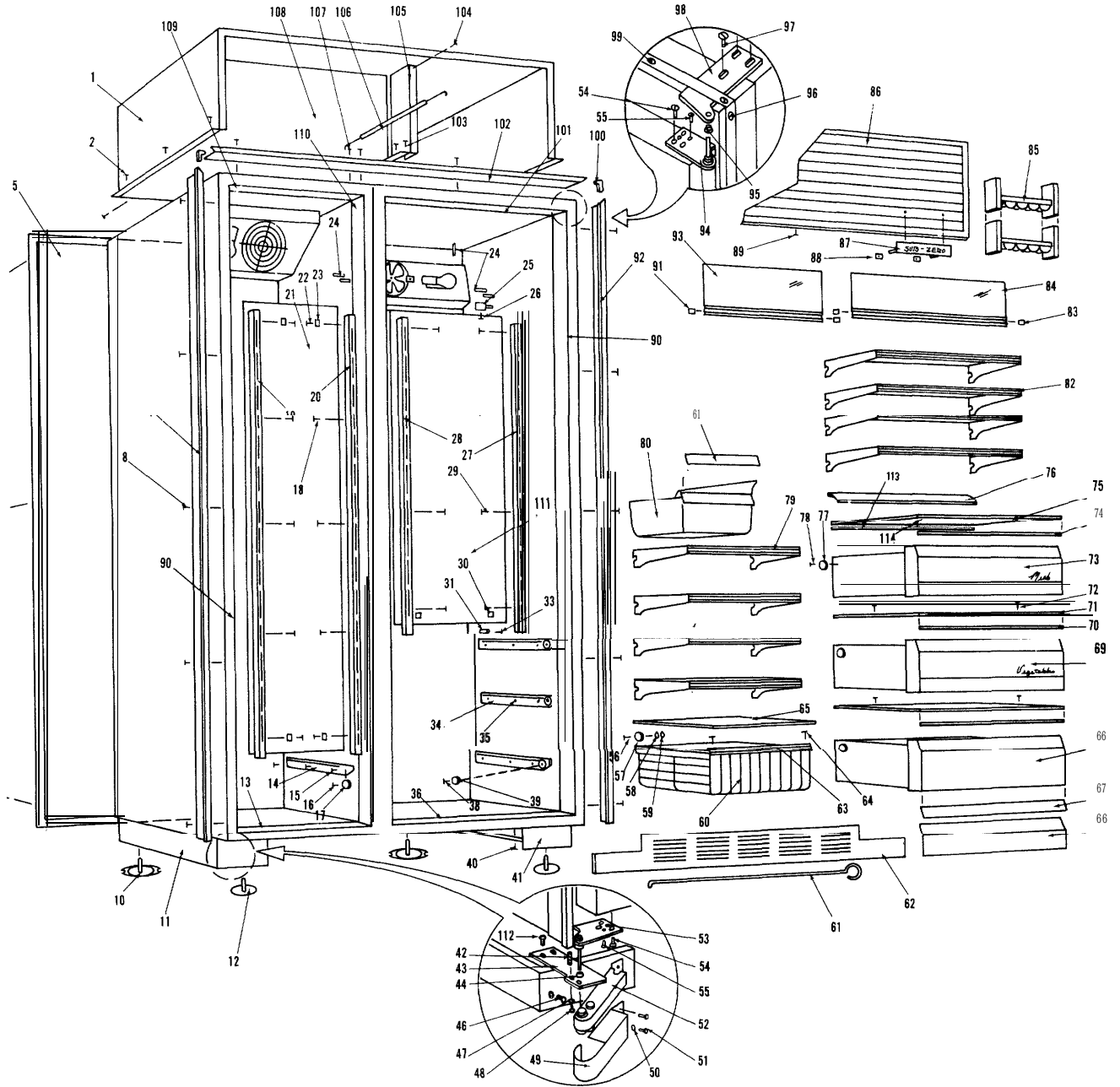

361 RFD SYSTEM VIEW

Item #	Part #	Description	Item #	Part #	Description
	6-20-002-0	Screw, #7-16 x 1/2 Pan Head	62	6-15-033-0	Wellnut, #10-32
2	6-11-012-0	Bolt, #10-32 5/8 Truss Head	63	6-11-032-0	Bolt, #10-32 x 3/4 Truss Head
3	6-15-007-0	Nut, #10A Self Retaining U-Type	64	0-21129-0	Refrigerator Fan Bracket
4	0-23197-0	Blower Bracket, 8-7/8	65	3-15-021-0	Fan Blade, 4"
	0-23151-0	Blower Wrapper	66	6-11-027-0	Bolt, #10-32 x 1/4 Round Head
	6-20-003-0	Screw, #10-12 x 5/8 Truss Head	67	3-01-232-0	Control Knob
	4-32-093-0	Defrost Terminating Thermostat	68	6-11-005-0	Bolt, #8-32 x 3/8 Truss Head
8	3-01-101-0	Accumulator, 1-1/4 x 8-7/8	69	3-01-234-1	Refrigerator Control
9	4-32-091-0	Defrost Heater Assembly	70	6-12-016-0	Plastic Cord Clip, 5/16 x 1/2
10	3-01-332-0	Drain Tube Heater, 28.5	71	4-20-017-0	Refrigerator Fan Motor, 23 Watt
11	3-13-003-0	Freezer Evaporator Coil, 4-1/2 x 6 x 9	72	3-05-003-0	Light Socket
12	6-18-001-0	Pop Rivet	73	3-03-003-0	Light Bulb, 40 Watt
13	6-15-013-0	Nut, 1/4-20 Hex S.S.	74	4-20-034-0	Light Switch Kit
14	6-24-007-0	Lock Washer, 1/4 S.S.	75	6-20-002-0	Screw, #7-16 x 1/2 Pan Head
15	0-23222-0	Fan Bracket, 7/8 x 3-1/2 x 8	76	3-22-016-0	Grommet, 3/16 x 7/16 x 9/32
16	4-20-016-0	Freezer Evaporator Fan Motor, 23 Watt	77	1-8017-00	Fan Bracket
17	6-11-027-0	Bolt, #10-32 x 1/4 Round Head	78	6-20-049-0	Screw, #8-32 x 3/8 Slotted Hex Type 25
18	3-15-006-0	Fan Blade; 5 Prop, 5-1/2	79	3-08-105-0	Defrost Timer
19	0-16218-2	Blower Cover w/Light Hole	80	6-20-001-0	Screw, #10-12 x 3/4 Pan Head
20	3-21-001-0	Gasket, 1/16 x 3/16 x 1/2	81	6-20-034-0	Screw, #6-20 x 1/2 Pan Head
21	6-20-012-0	Screw, #10-12 x 1/2 Truss Head	82	6-20-001-0	Screw, #10-12 x 3/4 Pan Head
22	3-14-007-0	Icemaker	83	4-15-059-0	Fan Guard Assembly
	3-14-008-0	Icemaker-Canadian Use Only	84	6-15-041-0	1/4-20 Nut
23	6-12-015-0	Wire Clamp; Stl w/Rub, 7/16	85	3-15-027-0	Fan Blade; 5 Prop, 7"
24	6-11-016-0	Bolt, 1/4 x 3/4 Hex Head	86	3-21-034-0	Neoprene Silencer, 7/8"
25	3-53-009-0	Fan Grille, 6-1/4	87	3-15-028-0	Condenser Fan Motor; 1.5 Watt, 4 Pole
26	4-32-118-0	Icemaker Wiring Harness	88	6-20-028-0	Screw, #8-18 x 1/2 Pan Head
27	3-05-003-0	Light Socket	89	3-02-229-0	Gray Power Cord
28	3-03-003-0	Light Bulb, 40 Watt	90	3-12-014-0	Condenser
29	3-52-011-0	Water Inlet Fitting Assembly	91	4-25-045-0	Heat Exchanger Assembly
30	3-52-003-0	Icemaker Nut; Nylon, 1/4	92	3-11-047-0	Compressor (AET1413A)
31	6-20-006-0	Screw, #8-32 x 1/2 Pan Head	93	3-09-008-0	Valve Cap
32	0-16200-0	Solenoid Bracket	94	3-09-001-0	Base Valve, 1/2 x 1-3/8
33	6-20-001-0	Screw, #10-12 x 3/4 Pan Head	95	6-15-009-0	Wellnut, #10-32
34	3-09-002-0	Solenoid Valve	96	6-15-022-0	Nut, 5/16-18 Hex
35	3-21-003-0	Water Valve Gasket	97	6-16-007-0	Sleeve, 5/16 x 7/16 x 7/8
36	3-52-021-0	Water Valve Fitting	98	3-15-017-0	Rubber Grommet, 15/16 x 1/25
37	3-52-022-0	Ball Sleeve	99	6-24-005-0	Flat Washer, 5/16
38	3-52-023-0	Compression Nut	100	3-52-005-0	Brass Insert
39	4-32-128-0	Cabinet Wiring Harness	101	3-52-012-0	Brass Insert, 3/16 x 9/32
40	3-42-076-0	Drain Pan Holder	102	3-11-051-0	Start Relay (GE3ARR12-WR17)
41	3-49-006-0	Drain Pan, 1.3 x 13.1 x 20	103	3-11-049-0	Overload (MRT22AHK-296)
42	6-20-015-0	Screw, #10-24 x 5/8 Round Head	104	6-11-034-0	Screw, Slot Head
43	2-6041-01	Condensate Heater Loop	105	3-11-063-0	Terminal Cover Strap
45	6-22-021-0	Stand-Off Heater	106	3-11-062-0	Terminal Cover
46	6-12-003-0	Plastic Tube Clamp, 1/4	107	3-01-405-0	Drier, 1/4 x .095
47	6-20-001-0	Screw, #10-12 x 3/4 Pan Head	108	6-20-001-0	Screw, #10-12 x 3/4 Pan Head
48	2-6006-09	Plastic Water Tube, 66	109	6-12-003-0	Plastic Tube Clamp, 1/4
49	1-6014-00	Freezer Drain Tube	112	6-20-032-0	Screw, #8-32 x 1/2 Truss Head
50	6-12-005-0	Plastic Tube Clamp, 5/8	113	6-20-008-0	Screw, #8-15 x 1/2 Truss Head
51	6-20-002-0	Screw, #7-16 x 1/2 Pan Head	114	2-6008-01	Water Inlet Tube, 4.5
52	1-6014-00	Refrigerator Drain Tube	115	6-20-033-0	Screw, #8-18 x 3/8 Pan Head
53	6-20-012-0	Screw, #10-12 x 1/2 Truss Head	116	6-12-012-0	Tube Clamp, 3/8 CPS
54	4-19-007-0	Drain Trough Assembly, 1.75 x 16.38	117	3-52-005-0	Brass Insert
55	6-20-009-0	Screw, #8-15 x 1-3/4 Truss Head	118	6-20-014-0	Screw, #8-15 x 3/8 Truss Head
56	2-8040-02	Evaporator Holder, 14-15/16	119	488646	Screw
57	2-6005-20	Refrigerator Evaporator Tubing, 5/16 x 7.77	120	625910	Bracket
58	4-16-012-0	Control Clamp	121	3-02-227-0	Refrigerator Switch Plug
59	6-15-003-0	Nut, #10-24 Hex S.S.	122	3-02-228-0	Freezer Switch Plug
60	6-11-003-0	Bolt, #10-24 x 1/2 Round Head	123	2-4013-10	Unit Fan Shroud
61	0-21101-0	Refrigerator Fan Shroud			

361 RFD SYSTEM VIEW

